



STRATEGIC PLAN FOR THE CARIBBEAN COMMUNITY 2015 - 2019: REPOSITIONING CARICOM

VOL. 2 - THE STRATEGIC PLAN

**CARICOM Secretariat
Turkeyen, Guyana**

3 JULY 2014

Prepared by Gwendoline Williams and Associates in collaboration with the CARICOM Secretariat and the Change Drivers in Member States and after consultations with a wide range of CARICOM Stakeholders. Funding was provided by the Department for International Development (DFID) of the United Kingdom as part of the wider Reform of CARICOM.

**STRATEGIC PLAN FOR
THE CARIBBEAN COMMUNITY**

2015 – 2019:

REPOSITIONING CARICOM

VOL. 2 OF THE STRATEGIC PLANNING DOCUMENTS

THE STRATEGIC PLAN

PREFACE

The Strategic Plan for the Community 2015 - 2019 is in direct response to the need to target “... *a narrow range of specified outcomes within specified timeframes, focusing on a few practical and achievable goals*” in relation to the regional development agenda. This is particularly important given the Community’s limited resources. However, the Strategic Plan has been prepared after consultation with the widest possible range of stakeholders and the intense engagement with Member States, Institutions, the CARICOM Secretariat and other stakeholders has resulted in a much wider mandate.

In that regard, the first Strategic Plan for the Caribbean Community outlines the strategic repositioning of the Community, and captures a *development agenda* going forward that encompasses: i) a review of development needs; ii) a Resilience Model for socio-economic progress; iii) strategies to renew the commitment to and strengthen actions for enhancing regional unity; and, iv) an agenda for the reform of governance mechanisms to achieve these two major forward thrusts. At the same time, as a framework for action, the Strategic Plan allows for selection of, and agreement on, the *narrow range* of actions that are pursued each year of the plan period in pursuit of the Region’s development goals. As well, the Plan outlines the implementation imperatives, strategic and change management modalities with the necessary monitoring, measurement and evaluation frameworks. The critical action now is ‘buy in’ and onward movement.

The Plan is in three Volumes. **Volume 1**, the Executive Plan, presents an abbreviated version of the full Plan for easy perusal. It includes an introductory section at Chapter 1; the full strategic framework at Chapter 2 (which is the same as Chapter 4 in the full plan); and a summary of the proposed management arrangements at Chapter 3 (Chapters 5, 6 and 7 in the full plan).

Volume 2 is the full Strategic Plan for the Caribbean Community 2015-2019 and is structured as follows: **Chapters 1 to 3** provide: i) the context of the Community; ii) a quick summary of the planning process engaged; and, iii) critical strengths, weaknesses and opportunities for the Community, after doing a wide ranging scan of the internal and external environments. **Chapter 4** is the heart of the Plan. It presents the vision, mission, core values and strategies for building resilience and unity and enhancing governance.

In order to transition from planning to implementation, each implementing agent of CARICOM (the Member States, the Institutions and the Secretariat) would need to draw from the Strategic Plan in designing its operational plan and annual plans. Thus **Chapter 5** presents examples of how the objectives of the Strategic Plan should inform the strategies, principal measures, targets, indicators, time frame and budget of each of the implementing agents. Indeed, it is strongly recommended, that a standard operating procedure be set in train, whereby each implementing agent viz. the Organs, CARICOM Secretariat, Community Institutions and Member States, presents its Operational Plan in conformity with the Strategic Plan and annually reports on progress and the way forward.

This will ensure that all in the Community and particularly the Heads of Government and citizenry are kept informed on the implementation of the Strategic Plan. This Chapter also emphasizes critical principles that must characterize the implementation process viz. subsidiarity, focus on goals/results, evidence-informed, equity, harmonization (bearing in mind differences among Member States), transparency, openness, and accountability. These principles must be consistently evident in the work of the Community to drive the Resilience Model.

Chapters 6 and 7 of the full Plan present frameworks for managing and measuring change. The **Appendices** contain key additional reference information such as an overview of the full planning process.

Volume 3 presents the technical appendices of the Plan, that is, reports of the data gathering instruments that informed the Plan. The technical appendices include: i) the full Environmental Scan; ii) the Country Reports arising from the National Consultations; iii) Report of Consultation with CARICOM Secretariat; iv) the report of the Telesurvey (conducted to garner the views of the wider citizenry of the Community); v) the Report of the Youth Online Survey; vi) the Analysis of the Regional Pictogram; vii) Stakeholder Map of the Planning Process; and viii) a summary description of the Institutions of the Community.

MESSAGE FROM THE CHAIRMAN OF THE CONFERENCE OF HEADS OF GOVERNMENT OF CARICOM

At the Thirty-Fifth Meeting of the Conference of Heads of Government held in Antigua and Barbuda, which I had the honour to host and Chair, CARICOM Heads of Government approved the Community's five-year Strategic Plan. "The Caribbean Community Five-Year Strategic Plan 2015-2019: Repositioning CARICOM" is the first ever Plan of its kind for our Community.

This Plan is the product of more than a year's work, piloted by a group of committed CARICOM professionals who undertook widespread consultations throughout our Member States and Associate Members and who distilled from those interactions, as well as from research, the Strategic Priorities and supporting strategies to move our Community forward.

This Plan has been devised at a time when threats to the sustainable development of our Region abound, be they financial, economic, social or environmental. Throughout our history, we have come up with solutions to defeat the most dire predictions and conquer the toughest challenges. In that regard, this Plan represents an essential strategic repositioning for our Community as we seek to secure our future in a rapidly changing and often hostile global environment.

The best - indeed the only - way to do this is by enhancing our Resilience: economic, social, environmental and technological. That theme of Resilience is at the very heart of this Strategic Plan. Together, we can, and will, not only survive but thrive, by enhancing our collective capacity to achieve economic stability and growth, a better quality of life for our people and sustainable development.

One of the enabling strategies in the Plan, Strengthening the CARICOM Identity and Spirit of Community, is one which I heartily endorse as an important element in the Plan's success. It is that spirit of oneness that brings us all together in celebrating the achievements of our people; that binds us to be our brother's keeper in the wake of natural disasters; and is now being called on to be brought to bear to assist in fulfilling the objectives and attaining the goals of this Strategic Plan.

Let us all recommit ourselves to the further strengthening of our integration movement and in doing so, build a resilient Community that provides a safe and prosperous life for all its people.

HONOURABLE GASTON BROWNE
PRIME MINISTER OF ANTIGUA AND BARBUDA

FOREWORD BY THE SECRETARY-GENERAL OF CARICOM

Our Caribbean Community (CARICOM) now has its first-ever Strategic Plan. The Plan was approved by the Conference of Heads of Government at its Thirty-Fifth Regular Meeting held in St John's, Antigua and Barbuda, July 2014.

This is an ambitious document, laying out a comprehensive Plan for repositioning the Community. The groundwork in preparing this Plan was laid, among other things, through extensive consultations with stakeholders throughout the Member States, Associate Members and with the Organs, Institutions and Agencies of the Community. Heads of Government, Ministers, the public services, the private sector, labour, civil society, the youth, all our Community Institutions and the Secretariat were canvassed for their insights. The final product has therefore emerged from the widest possible range of views and ideas.

The Plan identifies eight Strategic Priorities for the Community over the five-year period, 2015-2019, and key areas of intervention for each. The Strategic Priorities are: Building Economic Resilience; Social Resilience; Environmental Resilience; Technological Resilience; Strengthening the CARICOM Identity and Spirit of Community; and Strengthening Community Governance along with Coordinated Foreign Policy, and Research and Development and Innovation.

Arising out of the consultations, a number of areas of intervention are identified in the Plan but given our limited resources, the Heads of Government recognised the need to further prioritise. They therefore agreed on the following high-priority areas for focused implementation over the next five years:

- i. Accelerate implementation and use of the CARICOM Single Market and Economy (CSME);
- ii. Introduce Measures for Macro-economic Stabilisation;
- iii. Build Competitiveness and Unleash Key Economic Drivers to Transition to Growth and Generate Employment;
- iv. Human Capital Development;
- v. Advance Health and Wellness;
- vi. Enhance Citizen Security and Justice;
- vii. Climate Adaptation and Mitigation and Disaster Mitigation and Management;
- viii. Develop the Single ICT Space;
- ix. Deepen Foreign Policy Coordination (to support strategic repositioning of CARICOM and desired outcomes);
- x. Public Education, Public Information and Advocacy;
- xi. Reform of the CARICOM Secretariat, the Organs, Bodies, Institutions and Governance Arrangements.

Given that it is a Plan for the Community, the implementation phase will require the most efficient and effective use of our resources and calls for an increased level of co-ordination and collaboration among the Member States, the Community's Organs, Bodies, Institutions and the Secretariat. It will also require the support of all the stakeholders as we maintain the momentum of that process of consultation which was so critical to the development of the Plan.

It is clear that to fulfil the objectives, there will have to be an adjustment in the Community's methods of operation. This Plan is an integral part of a reform process underway in the Community which will include reviews of the Institutions and the restructuring of the Secretariat to accomplish the goals set out.

This reform process is dynamic and will require us to be proactive and responsive as we proceed, guided by a system of monitoring and evaluation of the progress that we make. This will ensure that we remain relevant and on the path of repositioning our Community to maximise the opportunities we have created through such mechanisms as the CARICOM Single Market and Economy (CSME) and to enhance our ability to integrate beneficially into the global arena.

I would like to express sincere gratitude to the team which made this Plan possible, especially Gwendoline Williams and Associates who led the way and in particular Ms. Maria Mason-Roberts for her lead role in preparing the Plan. The Change Drivers from our Member States and Associate Members played an instrumental role in the entire process as did the Internal Change Team Strategic Planning Sub-Group and other staff of the Secretariat. I also extend appreciation to the numerous stakeholders who participated in the consultative process throughout the Community; as well as our Community Institutions.

In going forward, that spirit of CARICOM unity exhibited throughout the entire consultative and planning process, is what we will need to ensure that this Plan succeeds in carrying us further along the road to sustainable growth and development and an improvement in the lives of the people of our Community.

Irwin LaRocque
Secretary-General, CARICOM

ACKNOWLEDGEMENTS

Two of the principles guiding the preparation of this Strategic Plan for the Caribbean Community were “stakeholder driven” and “knowledge based”. To this extent, the contributions of a wide range of Caribbean citizens must be acknowledged. These included:

- (a) **Key Informants** who brought their special expertise and years of involvement in the Caribbean enterprise to the table viz. Dr. Norman Girvan (deceased), Caribbean Academic, former Secretary-General of the Association of Caribbean States and fervent regionalist; The Most Hon. P.J. Patterson, former Prime Minister of Jamaica; Hon. Patrick Manning, former Prime Minister of Trinidad and Tobago; Hon. Winston Dookeran, Minister of Foreign Affairs of Trinidad and Tobago; Professor Anthony Gonsalves of the University of the West Indies; and H.E. Dr. Patrick Antoine, Ambassador of Grenada to CARICOM and Change Driver.
- (b) **The Change Drivers** who represented the hub of activity to bring the views of the wider citizenry on board through National Consultations and who read and reread and had their nationals read and re-read various drafts of the Plan to ensure it brought into being a Regional Plan that responded to national needs and interests. These Change Drivers are:

Antigua and Barbuda	H.E. Dr. Clarence Henry, Ambassador to CARICOM
The Bahamas	H.E. Mr. Picewell Forbes, Plenipotentiary Representative to CARICOM
Barbados	H.E. Mr. Robert Morris, Ambassador to CARICOM
Belize	Audrey Wallace, Chief Executive Officer, Office of the Prime Minister
Dominica	H.E. Mr. Felix Gregorie, Ambassador to CARICOM
Grenada	H.E. Dr. Patrick Antoine, Ambassador to CARICOM
Guyana	H.E. Ms. Elisabeth Harper, Ambassador to CARICOM
Haiti	H.E. Mr. Peterson Benjamin Noel, Ambassador to CARICOM
Jamaica	Ms. Angella V. Comfort, Director, Caribbean and Americas Department, Ministry of Foreign Affairs and Foreign Trade
Montserrat	Mr. Claude Hogan, Director, External Affairs and Trade
St Kitts and Nevis	Hon. Richard Skerritt, Minister of Tourism and International Transport
Saint Lucia	Dr. Alison Gadjadhar, Permanent Secretary, Office of the Prime Minister

St Vincent and the Grenadines	H.E. Mr. Ellsworth John, Ambassador to CARICOM
Suriname	H.E. Ms. Manorma Soeknandan, (former) Ambassador to CARICOM H.E. Mr. Michael Kerpens, Ambassador at Large, Chef de Cabinet of the Minister of Foreign Affairs
Trinidad and Tobago	H.E. Mr. Mervyn Assam, Ambassador Extraordinary and Plenipotentiary with responsibility for Trade and Industry
British Virgin Islands	Ms Sylvia Moses, Director, International Affairs
Turks and Caicos Islands	Hon. Ricardo Don-Hue Gardiner, Minister of Border Control and Labour.

- (c) **All Participants in National Consultations/or Special Meetings** during the period of the national consultations. These included from 15 Member States and 2 Associate Members: Prime Ministers and Cabinets; Leaders of the Opposition; Other Members of Parliament; Representatives of the Private Sector, Employers and Trade Unions; Youth Representatives; Other Civil Society Groups; Representatives of Tertiary Level Institutions; Labour Organisations.
- (d) **CARICOM Youth Ambassadors** who mobilised the contribution of young people to the deliberations on the Plan, including through the Youth Online Survey.
- (e) **Respondents to the Telesurvey and the Youth Online Survey**, who by their participation allowed the Plan to benefit from the views of a wide cross section of nationals of the Community, who otherwise might not have been heard.
- (f) **Leaders and Representatives of the Regional Institutions**, who participated as contributors and drafters of the Plan, from the vantage point of the special expertise of their various Institutions.
- (g) **The Leadership and Technical Officers of the Caribbean Community (CARICOM) Secretariat**, who not only contributed technical information, but gave their views as citizens of the Community. Within this group, special acknowledgement must be given to the Strategic Planning Sub-Group members who were involved in the drafting task and who also collated contributions of other representatives of the Secretariat.
- (h) **The British Department for International Development (DFID)**, which provided resource support to make the initiative possible and technical advice which informed the progress of the project.
- (i) **The Change Facilitation Team** which had the responsibility for designing and implementing the planning process and collating the inputs from all sources to arrive at the Strategic Plan.
- (j) **All CARICOM Nationals** who commit to contribute to Plan implementation, and who will be beneficiaries of such implementation.

To Caribbean unity, resilience and prosperity.

LIST OF ACRONYMS AND ABBREVIATIONS

ACIS	Advance Cargo Information System
ACP	African, Caribbean and Pacific Group of Countries
ACS	Association of Caribbean States
ACTI	Association of Caribbean Tertiary Institutions
APIS	Advance Passenger Information System
CARDI	Caribbean Agricultural Research and Development Institute
CARICAD	Caribbean Centre for Development Administration
CARICOM	Caribbean Community
CARIFORUM	Caribbean Forum of ACP States
CARIFTA	Caribbean Free Trade Association
CARPHA	Caribbean Public Health Agency
C@ribNET	Caribbean Research and Education Network
CASSOS	Caribbean Aviation Safety and Security Oversight System
CCA	Committee of CARICOM Ambassadors
CCC	CARICOM Competition Commission
CCCCC	Caribbean Community Climate Change Centre
CCJ	Caribbean Court of Justice
CCRIF	Caribbean Catastrophe Risk Insurance Facility
CCS	Caribbean Community Secretariat
CDB	Caribbean Development Bank
CDF	CARICOM Development Fund
CDEMA	Caribbean Disaster Emergency Management Agency
CDM	Comprehensive Disaster Management
CEDA	Caribbean Export Development Agency
CKLNA	Caribbean Knowledge and Learning Network Agency
CIMH	Caribbean Institute of Meteorology and Hydrology
CLE	Council of Legal Education
CMO	Caribbean Meteorological Organisation
COFCOR	Council for Foreign and Community Relations
COFAP	Council for Finance and Planning
COHSOD	Council for Human and Social Development
CONSLE	Council for National Security and Law Enforcement
COTED	Council for Trade and Economic Development
CREDP	Caribbean Renewable Energy Development Programme

CRFM	Caribbean Regional Fisheries Mechanism
CRITI	Caribbean Regional Information and Translation Institute
CROSQ	Caribbean Regional Organisation for Standards and Quality
CRSP	Caribbean Regional Strategy Paper
CSME	CARICOM Single Market and Economy
CTU	Caribbean Telecommunications Union
CYA	CARICOM Youth Ambassador
CYDAP	CARICOM Youth Development Action Plan
CXC	Caribbean Examinations Council
DFID	Department for International Development (of the United Kingdom)
ECLAC	Economic Commission for Latin America and the Caribbean
EMC	Executive Management Committee
EPA	Economic Partnership Agreement
EU	European Union
FCR	Foreign and Community Relations (Directorate of the CARICOM Secretariat)
FDI	Foreign Direct Investment
GHG	Greenhouse Gas
GDP	Gross Domestic Product
HGC	Conference of Heads of Government of the Caribbean Community
HIV/AIDS	Human Immunodeficiency Virus/Acquired Immunodeficiency Syndrome
HSD	Human and Social Development (Directorate of the CARICOM Secretariat)
ICT	Information and Communications Technology
IDB	Inter-American Development Bank
IDP	International Development Partner
IMF	International Monetary Fund
IMPACS	Implementation Agency for Crime and Security
MDG	Millennium Development Goal
NCD	Non-Communicable Disease
NGO	Non-Governmental Organisation
OAS	Organisation of American States
ODSG	Office of the Deputy Secretary-General (of the CARICOM Secretariat)
OECS	Organisation of Eastern Caribbean States

OGC	Office of the General Counsel (of the CARICOM Secretariat)
OSG	Office of the Secretary-General (of the CARICOM Secretariat)
OTN	Office of Trade Negotiations (of the CARICOM Secretariat)
PANCAP	Pan Caribbean Partnership Against HIV/AIDS
PPP	Public Private Partnership
RCEP	Regional Comprehensive Economic Partnership (in Asia)
RDDS	Regional Digital Development Strategy
RI	Regional Integration
RMTA	Resource Mobilisation and Technical Assistance Unit (of the CARICOM Secretariat)
RTC	Revised Treaty of Chaguaramas
SIRI	System of Indicators for Regional Integration
SMC	Senior Management Committee (of the CARICOM Secretariat)
SME	Small and Medium-Sized Enterprises
SPRED	Strategic Plan for Regional Economic Development
SPS	Sanitary and Phyto-Sanitary Measures
TASU	Technical Action Services Unit (of the CARICOM Secretariat)
TEI	Trade and Economic Integration (Directorate of the CARICOM Secretariat)
TISA	Trade in Services Agreement
TTIP	Trans-Atlantic Trade and Investment Partnership (between the United States and the European Union)
USD	US Dollar
UWI	University of the West Indies
WEF	World Economic Forum
WB	World Bank
WTO	World Trade Organisation

DEFINITION OF KEY TERMS

CARIBBEAN COMMUNITY	The Caribbean Community is an international organisation, established by the Treaty of Chaguaramas (1973)
RESILIENCE	The ability to protect against and recover from any eventuality
PROPORTIONALITY	Competence is delegated in proportion to the need for collective regional action where national action is not sufficient to address the problem with the degree of effectiveness required
SUBSIDIARITY	Decisions which are best taken and implemented at the national level or local levels remain within the jurisdictions at those levels
TECHNOLOGICAL RESILIENCE	The ability to adapt and create new products in the future. The use of technology in all productive sectors; with access available to citizens and visitors.

LIST OF FIGURES & TABLES

LIST OF FIGURES

- FIGURE 1: MEMBER STATES OF THE CARIBBEAN COMMUNITY
- FIGURE 2: SIX INTEGRATED STRATEGIC PRIORITIES OF THE RESILIENCE MODEL
- FIGURE 3: THE STRATEGIC FRAMEWORK VALUE CHAIN
- FIGURE 4: DESCRIPTION OF THE IDEAL CARIBBEAN PERSON
- FIGURE 5: A STRATEGIC PLAN FOR A COORDINATED COMMUNITY
- FIGURE 6: PRINCIPLES OF IMPLEMENTATION
- FIGURE 7: THE RBM LOGIC - THE RESULTS CHAIN
- FIGURE 8: THE DESIRED STATE FOR THE COMMUNITY
- FIGURE 9: THE FOUR QUADRANTS OF CHANGE MANAGEMENT
- FIGURE 10: THE ORGANISATIONAL CHANGE PROCESS

LIST OF TABLES

- TABLE 1: CARICOM MEMBER STATES REGIONAL COUNTRY PROFILE (VARIOUS SOURCES)
- TABLE 2: RECOMMENDATIONS FOR STRENGTHENING THE CARICOM SECRETARIAT
- TABLE 3: EXAMPLE OF OUTPUT AND OUTCOME INDICATORS FOR M & E OF THE STRATEGIC PLAN
- TABLE 4: SAMPLE INDICATORS FOR DEVELOPING A SIRI MODEL
- TABLE 5: A CHANGE MANAGEMENT FRAMEWORK TO SUPPORT IMPLEMENTATION OF THE COMMUNITY STRATEGIC PLAN

TABLE OF CONTENTS

SECTION A: Where Have We Been? Where Are We Now? Why?.....1

1.0 INTRODUCTION.....2

1.1 The Imperative for Getting Plan Implementation Right – Where Are We Now?.....3

1.2 Where We Wish To Be?.....6

1.3 What is the Space for CARICOM?.....7

1.4 Overview of the Strategic Planning Process.....8

2.0 OVERVIEW OF CARICOM.....10

2.1 The Treaty of Chaguaramas10

2.2 Membership and Structure of the Community.....11

2.3 The Stakeholders of the Community.....13

2.4 The Services of the Community.....16

3.0 STRATEGIC REVIEW & ANALYSIS.....18

3.1 The Global Context.....18

3.2 The Regional Context.....20

SECTION B: Where Do We Wish To Be?.....26

4.0 THE STRATEGIC FRAMEWORK.....27

4.1 CARICOM’s Vision, Mission & Core Values.....27

4.1.1 Vision.....27

4.1.2 Mission.....27

4.1.3 The Core Values.....28

4.2 The Strategic Priorities to 2019.....29

4.2.1 Building Economic Resilience - Stabilisation and Sustainable Economic Growth and Development.....33

4.2.2 Building Social Resilience – Equitable Human and Social Development.....40

4.2.3 Building Environmental Resilience.....45

4.2.4 Building Technological Resilience.....48

4.2.5	Strengthening the CARICOM Identity and Spirit of Community.....	50
4.2.6	Strengthened Governance Arrangements within CARICOM.....	55
4.2.7	Enabling Resilience: Coordinated Foreign and External Relations and Research and Development and Innovation.....	63
4.3	Strategic Goals and Objectives to 2019.....	65
SECTION C:	How Will We Get Where We Wish To Be?.....	68
5.0	THE STRATEGIC IMPLEMENTATION FRAMEWORK.....	69
5.1	Strategic Implementation Framework for CARICOM 2015 – 2019.....	72
5.2	Enabling Implementation: HR, Budget, Operating Systems, Monitoring and Evaluation.....	94
5.2.1	Human Resource Capacity and Capability.....	94
5.2.2	Sustained Financing.....	95
5.2.3	Establish a Robust Communications Infrastructure and Network.....	96
5.2.4	Efficient Operating Systems.....	98
5.2.5	Monitoring, Evaluation & Reporting.....	99
5.3	Considerations for the Way Forward.....	100
5.4	The Role of the CCS Going Forward.....	106
SECTION D:	How Do We Know We Have Arrived?.....	115
6.0	THE STRATEGIC MANAGEMENT FRAMEWORK.....	116
6.1	Approaches to Monitoring and Evaluation.....	116
6.1.1	Results-Based Management.....	116
6.1.2	Measuring Integration – The Siri Model.....	119
6.2	Developing the Monitoring and Evaluation Framework for the Strategic Plan.....	121
6.3	Developing a System of Regional Indicators for CARICOM.....	124
SECTION E:	How Do We Remain in a State of Renewal?.....	126
7.0	THE CHANGE MANAGEMENT FRAMEWORK.....	127
7.1	Introduction.....	127
7.2	Charting the Path of Implementation – Developing the Community Change Management Strategy.....	129
7.2.1	A Model for Charting the Change Process in Plan Implementation...129	
CONCLUSION.....		137

APPENDICES.....	138
Appendix 1: Overview of the Planning Process.....	139
Appendix 2: List of Community Institutions and Associate Institutions.....	149
Appendix 3: Snapshot of Key Achievements of the Community.....	150
Appendix 4: SWOT Analysis for the Community.....	157

SECTION A

- ① **Where Have We Been?**
- ② **Where Are We Now?**
- ③ **Why?**

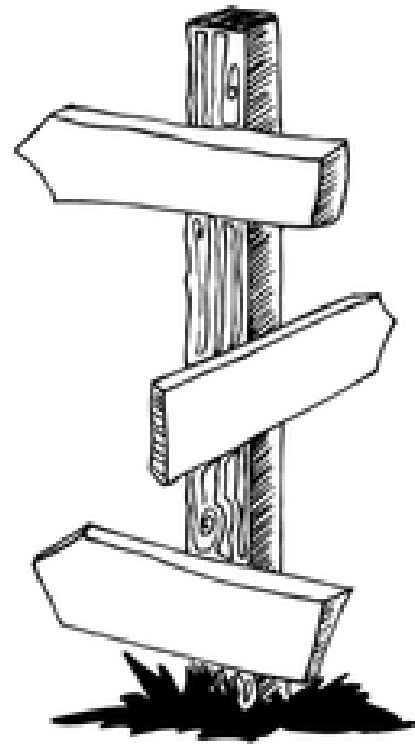

1.0 INTRODUCTION

Our Caribbean civilization has taken a battering on the social and economic fronts largely on account of the global economic downturn of September 2008 and continuing, the frequency and severity of natural disasters, and the self-inflicted home-grown challenges arising from the regional insurance and indigenous banking melt-down, and unacceptable levels of serious crimes. It is evident to all reasonable persons of discernment that our region would find it more difficult by far to address its immense current and prospective challenges unless its governments and peoples embrace strongly a more mature, more profound regionalism. That ought to be a noise in the blood, an echo in the bone of our Caribbean civilisation.

Dr. the Honourable Ralph E. Gonsalves, Prime Minister of St. Vincent and the Grenadines and Chair of CARICOM, June 2014¹

"If we did not have CARICOM, we would have to invent it"

Participant at a Member State consultation for developing the CARICOM Strategic Plan 2015 - 2019, September 2013

Even as the Caribbean Community (CARICOM) celebrated its 40th year, the Member States of the Community stressed the need for a "refocusing, redirection, and reorganisation of the Community"² to move the Community forward and reignite the flames of regional integration. This mandate resonates with the decision and direction of the Heads of Government at their Twenty-Third Inter-Sessional in March 2012 *"to re-examine the future direction of the Community and the arrangements for carrying [it] forward which would include the role and function of the Secretariat"*, and further that a strategic plan for the Community should be prepared.

In response to this decision of the Conference, the Community has embarked on a Reform Process which anticipates two (2) major outcomes³, viz,

- (a) a 5-year Strategic Plan for the Community;
- (b) a transformed Secretariat [and Community] with strategic focus, implementation capacity and strengthened corporate functions guided by the approved Community Strategic Plan.

¹ **"Free Movement of Community Nationals, the CCJ, Shanique Myrie, Community Law and Our Caribbean Civilisation"**. Distinguished Lecture Series of the University of the West Indies, St. Augustine, Trinidad and Tobago, June 17, 2014

² Terms of Reference: Change Facilitator, p.1

³ Ibid, p. 2

1.1 The Imperative for Getting Plan Implementation Right – Where Are We Now?

The significance of the timing of the preparation of the first Strategic Plan for the Community is not lost, as it coincides with one of the most challenging and dynamic economic and social epochs in the history of the post-independent sovereign States that comprise the Community.

The Environmental Scan for the Strategic Plan has extensively highlighted the overall economic decline in CARICOM and the dire consequences for sustainable development and the quality of life of the peoples of the Region (see **Table 1** for a current profile of CARICOM Member States). Ultimately, the effects of poor economic performance are manifest in the standard of living for the populations, especially the poor and vulnerable who are unable to meet their basic needs or to take advantage of educational and other opportunities that would enable the 'climb out of poverty', thus steering clear of various forms of social dislocation and environmental degradation.⁴

In order to address with urgency the crisis of development depicted, there is need to chart this journey of Plan implementation, first conceiving it as essentially a systems-wide change process that has to be managed with a clear sense of strategy and day-to-day monitoring, using the 'building blocks' as modes of tracking along the lines of the following questions:

1. Where have we been over time as diverse actors in the pursuit of regional integration; how effective have been our efforts, and from whose perspective?
2. Where are we now and what are the policy and strategy issues that impact us? Where are we expected to be in light of the agenda for reform of the regional integration process?
3. Where do we wish to be in the future?
4. Will the development of the Community's Strategic Plan get us to where we wish to be?

⁴ CDB Report as summarized in Express Newspaper commentary by Journalist Rickey Singh, February 2013

5. How would we know that we have arrived, bearing in mind the need for agreed performance indicators and outcome/impact measures?
6. To the extent that success is achieved, how do we propose to sustain successful Plan implementation?

TABLE 1: CARICOM MEMBER STATES REGIONAL COUNTRY PROFILE (VARIOUS SOURCES)

Member State	ECONOMIC			SOCIAL		TECHNOLOGICAL		POLITICAL***				DEMOGRAPHIC		
	GDP per Capita (US\$) 2012	Debt to GDP Ratio 2012	Doing Business Indicators Rank 2012 *	Human Development Rank 2012**	% Population Below Poverty Line***	Internet Penetration 2012	Mbps Broadband Download Speed 2012	Type of Gov't 2012***	Date of last election	Due Date of next election	Embrace of the CCJ***		Area Square KM	Population 2012 est.
											OJ^	AJ^		
Antigua and Barbuda	13,401	97.8	63	HHD 67	18.4 (2006)	82.0%	3.46	FMP	2009	2014	√;	-	442	90,313
The Bahamas	23,417	52.6	77	HHD 49	n/a	45.3%	9.13	US/CMP	2012	2017		-	13,962	362,765
Barbados	16,307	70.4	88	VHHD 38	19.3 (2010)	71.8%	5.72	CMP	2012	2017	√	√	431	278,550
Belize	4,386	81.0	105	MHD 96	41 (2009)	22.8%	3.30	CMP	2013	2018	√	√	22,966	327,719
Dominica	7,022	72.3	68	HHD 72	28.8 (2009)	51%	2.60	PR	2010	2015	√	-	751	73,126
Grenada	8,133	105.4	106	HHD 63	37.7 (2008)	35%	7.00	CMP	2013	2018	√	-	345	109,011
Guyana	3,596	60.4	114	MMD 118	36 (2006)	30.3%	--	US/SPR	2010	2015	√	√	215,083	744,768
Haiti	1,300	15.4	174	LHD 161	n/a	9%	4.35	US/SPR	2011	2015		-	27,748	9,801,664
Jamaica	5,526	143.3	90	HHD 85	16.5 (2009)	54.7%	5.43	CMP/D	2011	2016	√	-	10,991	2,889,187
Montserrat	12,825	4.3	--	--	36 (2009)	22%	--	CMP	2010	2015	√	-	102	6,200
St. Kitts and Nevis	12,869	144.9	96	HHD 72	21.8 (2008)	44%	2.65	FMP/CMP	2010	2015	√	-	267	50,314
Saint Lucia	7,509	78.6	53	HHD 88	28.8 (2006)	35%	6.80	CMP	2011	2016	√	-	616	161,557
St. Vincent and the Grenadines	6,637	68.3	75	HHD 83	30.2 (2007)	73.2%	--	CMP	2010	2015	√	-	392	103,869
Suriname	9,339	18.6	164	MHD 105	n/a	33.7%	3.19	LD	2010	2015	√	-	163,820	491,989
Trinidad and Tobago	17,935	35.7	69	HHD 67	17 (2005)	53.2	10.79	PR	2010	2015	√		5,128	1,222,505

Notes:
Source: International Monetary Fund (IMF); Central Intelligence Agency (CIA); internetworldstats (for Broadband downloads comparable data for Guyana, Montserrat and St. Vincent and the Grenadines was unavailable) and other sources.
* Among 185 assessed countries in 2012; comparable data for Montserrat was unavailable.
** VHHD - Very High Human Development; HHD - High Human Development; MHD - Medium Human Development; LHD - Low Human Development
*** Source: CARICOM Secretariat. LD - Liberal Democracy; FMP - Federal Monarchy Parliamentary System; CMP - Constitutional Monarchy Parliamentary System; US - Unitary State; D - Democracy; PR - Parliamentary Republic; SPR - Semi-Presidential System Republic.
^ OJ - Original Jurisdiction; AJ - Appellate Jurisdiction

1.2 Where We Wish To Be?

Using a Resilience Model, the Plan succinctly highlights the regional integration policy measures and governance modalities for economic turnaround and cultural transformation in the Community. It is empowered by a Vision, Mission and Core Values for renewing the spirit of community in CARICOM. Further, there is a delineated strategy that enunciates the key policy priorities - economic, social, technological and environmental - as imperatives to take the Community forward.

Systematically managing how these resilience-driven priorities would be implemented is a critical success factor in Plan implementation. The Change Management Strategy is needed in that regard to guide the implementation process.

The Change Management Strategy as envisaged, is 'time sensitive' (see Chapter 7), as the Community's current state of economic decline and attendant development problems must be moved rapidly to the 'desired state' of economic transformation and restored human development that is 'matched' by a more efficient and effective CARICOM architecture. This journey to the 'desired state' is to take place in the first instance, within a five-year time span, 2015-2019. This span of time for implementation can be considered a period of transition during which time the policy and planning undertaken for purposes of Plan implementation can be tracked, supported as well as monitored and evaluated.

The fundamental question is a simple yet complex one:

How does the Region unify and rally around the creative talents of its people, foster innovation and implement mechanisms to unleash the growth potential for its Member States...all whilst ensuring the most vulnerable are not neglected?

In response, the six-part broad strategic framework of the Resilience Model, has emerged from a highly participatory discourse among a wide range of stakeholders and represents an agreed upon *development agenda* for the Community which, in reality, extends beyond the five-year Plan period. In this context, the Plan provides a holistic framework to guide the actions of the CARICOM Organs, Institutions, Bodies and Member States to address the critical needs expressed in consultation with stakeholders and Community nationals.

The intent is to create the favourable conditions for reducing poverty in the Region, unleashing the growth drivers of the Region's economies and building CARICOM Unity. To that end, the strategic focus is to build social, economic, environmental and technological resilience of Member States; imbue the Regional Identity and Spirit of Community; and strengthen Governance arrangements for greater efficiency and effectiveness of the CARICOM architecture.

1.3 What is the Space for CARICOM?

CARICOM has had significant achievements over the past four decades, for example, in the areas of education, health, disaster management and trade. Regional initiatives such as the CARICOM Single Market and Economy (CSME), the Caribbean Court of Justice, (CCJ) functional cooperation in education, and the HIV/AIDS response, have borne fruit in Member States and continue to be part of the human development landscape. More recent achievements include the regional energy policy and an enhanced regional disaster management strategy. These advancements, coupled with the many and varied strengths of the people of the Region, and the rich natural resource base, are the spring board for advancing the Region over the next five years and beyond.

Among stakeholders across the Region, there is recognition of the value of being together as small states in an increasingly competitive world. This perspective is also shared by several of the Region's International Development Partners (IDPs) and a range of International Financial Institutions (IFIs).

This is a space for CARICOM to provide specific benefits for the people of the Region that will demonstrate that regional integration represents a vital strategy for economic recovery and growth and social development for each Member State, away from the current crisis of debt, low growth, high costs, unemployment and persistent poverty plaguing many Member States.

This is the space for CARICOM to promote and provide a range of services and products that can positively impact the lives of the people of the Community, working towards the broad development agenda within this Plan in a targeted and systematic manner. For example, to realize the full benefits of the single market and production base and global competitiveness for the Region that would mean increased employment opportunities, growth of new business (small, medium and large) and/or functional cooperation that brings technology to the people or ensures universal access for all, to quality health services.

Stakeholders agree that the small states of the Community have few options to overcome their inherent vulnerabilities, for example, to external economic shocks and natural disasters. In that regard, steps to strengthen CARICOM and improve its efficiency and effectiveness are critical for the survivability of its Member States.

Indeed, to play its role in enabling resilience and prosperity for the Region, reform of CARICOM is needed to ensure that facilitative governance and institutional arrangements are in place, the required resources are readily available, and there is public buy-in and commitment.

Therefore, ‘ownership’ of, and commitment to, implementing the Plan among Heads of Government, the Organs and Institutions of the Community, stakeholders and the wider population, is perhaps the most critical success factor going forward. In that regard, there are specific measures (some already in place) to ensure such commitment exists, for example, through the role to be played by the Chair of Conference, the Bureau, the Secretary-General, Change Drivers in Member States and Heads of Community Institutions.

1.4 Overview of the Strategic Planning Process

The strategic direction to 2019 as proposed, is predicated on a *triangulation* of findings, priorities and action items emanating from:

- (a) The voice of the peoples of the Region *via* National Consultations in the fifteen (15) Member States and in two (2) Associate Members, a Regional Tele-Survey (15 Member States and 5 Associate Members), a Youth Online Survey, written submissions and key informant interviews;
- (b) Various studies commissioned by the Secretariat as well as Policies and Programmes adopted by the Community; and
- (c) Several leading world authorities.

See **Appendix 1** for a full description of the planning process.

Across the data sources, the common themes/gaps which emerged consistently were the need to:

- (a) Aggressively promote regional integration and the CARICOM agenda;
- (b) Assure the growth and development of the Community through effective interventions that address the challenging economic situation of Member States, through tapping the sectors with potential for growth, production and increased trade, intra-regional transportation, human capacity development, free movement of skills, youth development, and food and nutrition security; and
- (c) Strengthen the institutional arrangements to create a much more effective CARICOM.

These ideas are interoperable and form the basis for the Strategic Framework elucidated at Chapter 4 of this Plan, to be implemented over the planning period to 2019.

2.0 OVERVIEW OF CARICOM

2.1 The Treaty of Chaguaramas

The Caribbean Community (CARICOM) is an international organisation, established by Treaty. CARICOM was originally established by the Treaty of Chaguaramas, signed on 4 July 1973. In 1989, the decision was made to establish the CARICOM Single Market and Economy (CSME) as an impetus for “deepening the integration movement to better respond to the challenges and opportunities presented by globalization”. The establishment of the CSME gave rise to the need to amend the Treaty of Chaguaramas. The Revised Treaty of Chaguaramas Establishing the Caribbean Community, including the CARICOM Single Market and Economy (RTC), was signed in 2001.

The RTC provides the legal basis for the Community and sets out its objectives, its structure and key areas of endeavour. It also provides for the decision-making authority of the Organs and Bodies of the Community which decisions contribute to the development of Community law and policy.

The RTC reinforced the main ‘pillars’ of the Community viz. economic integration, functional cooperation, and foreign policy coordination. In 2005, the Conference of Heads of Government established Security as the fourth pillar of the Community coming out of the growing threat to citizen security and other regional assets and institutions.

The objectives of the Community are identified in Article 6 of the Revised Treaty viz:

- i. improved standards of living and work;
- ii. full employment of labour and other factors of production;
- iii. accelerated, coordinated and sustained economic development and convergence;
- iv. expansion of trade and economic relations with Third States;
- v. enhanced levels of international competitiveness;
- vi. organisation for increased production and productivity;
- vii. the achievement of a greater measure of economic leverage and effectiveness of Member States in dealing with third States, groups of States and entities of any description;

- viii. enhanced co-ordination of Member States' foreign and [foreign] economic policies; and
- ix. enhanced functional cooperation, including -
 - (a) more efficient operation of common services and activities for the benefit of its peoples;
 - (b) accelerated promotion of greater understanding among its peoples and the advancement of their social, cultural and technological development;
 - (c) intensified activities in areas such as health, education, transportation, telecommunications.

The objectives of the RTC well outline the economic aspirations of regional integration. However, there is the view among many stakeholders that these objectives need to be expanded to articulate more clearly, the desired human and environmental outcomes for the Community. Indeed, there is, as is expected, ongoing review and amendment of the Treaty as the environment changes; for example, the need to take account of the accelerated integration among the OECS Members.

As the Community matures, it is anticipated that strong mechanisms will exist for dialogue and decision-making that ensure that the legislative environment for development is enabling and efficient.

2.2 Membership and Structure of the Community

Membership in the Community comprises fifteen Member States (see **Figure 1**), and five Associate Members viz, Anguilla, Bermuda, British Virgin Islands, Cayman Islands and Turks and Caicos Islands.⁵

There is interest among several countries in the wider Caribbean to attain Membership or Associate Membership of the Community. The issues related to both deepening and widening the Community are part of an extant rich dialogue, which will continue over the Plan period, as part of the discourse on the future for the Region.

The Community structure includes *Organs, Bodies and Institutions*. The Organs of the Community are the Conference of Heads of Government and the Ministerial Councils with responsibility for key policy areas, as set out in the Treaty. The Organs are the decision-making bodies of the Community.

⁵ http://www.caricom.org/jsp/community/member_states.jsp?menu=community&prnf=1

The *Principal Organs* are: The Conference of Heads of Government (and its Bureau); and the Community Council of Ministers (The Community Council).³³

FIGURE 1: MEMBER STATES OF THE CARIBBEAN COMMUNITY



These Principal Organs are assisted by five Organs, three Bodies and the CARICOM Secretariat, which is the *Principal Administrative Organ*.

The five Organs are the:

- ⦿ Council for Trade and Economic Development (COTED).
- ⦿ Council for Foreign and Community Relations (COFCOR).
- ⦿ Council for Human and Social Development (COHSOD).
- ⦿ Council for Finance and Planning (COFAP).
- ⦿ Council for National Security and Law Enforcement (CONSLE).

The three Bodies are the:

- ⦿ Legal Affairs Committee (LAC) (*comprising Attorneys-General and Ministers of Legal Affairs*) advises the Organs and Bodies.
- ⦿ Budget Committee (*reports to the Community Council*).
- ⦿ Committee of Central Bank Governors (*advises the COFAP*).

The CARICOM Secretariat (CCS), as the Principal Administrative Organ of the Caribbean Community, has a mandate to⁶ provide a wide range of services to promote regional integration in the Community. These services include research and development; co-ordination of the activities of donor agencies, international regional and national institutions; project development and management; dissemination of information; foreign and community relations; technical cooperation and servicing of meetings of the various Organs of the Community.

⁶ Article 25 "Functions of the Secretariat" -- Revised Treaty of Chaguaramas

There is also a Court of the Community, the CCJ, which in its original jurisdiction has the exclusive and compulsory jurisdiction to determine disputes on the interpretation or application of the Revised Treaty. The Original Jurisdiction judgments to date, have confirmed that the CCJ is empowered to review the decisions of the Organs and Bodies and the Secretary-General, and to “enforce the rule of law and to render the RTC effective”.⁷

The Community has also established Institutions which are specialist technical agencies and which form part of the wider Community. They have been described by one stakeholder as ‘CARICOM in Action’. Certain Institutions are created by the Revised Treaty, such as the CARICOM Development Fund (CDF) and the CARICOM Competition Commission (CCC) and are essential to the operations of the Community. Other Institutions were created to support the implementation of mandates of the Revised Treaty, including the CSME, such as the Caribbean Regional Organisation for Standards and Quality (CROSQ). A list of Community Institutions is at **Appendix 2** and a summary of each of the Institutions is at **Vol. III Technical Appendices**.

The Headquarters of CARICOM is located in Georgetown, Guyana, where the Secretariat is located. The Secretariat has an office in Barbados where the Office of Trade Negotiations (OTN) and the CSME Unit are located; and in Jamaica where a second office of the OTN is located.

The Organs and Institutions have been subjected to review over the years towards improving their efficiency and effectiveness. Indeed, this remains a desired outcome of the reform process as noted above. For example, the management of the meetings of the Organs, their decision-making process, and monitoring of results produced, is an ongoing concern among the Ministers and Officials participating in these fora. Reviews have been undertaken of the Security Institutions; the Health Institutions and of the Secretariat within the last five years, and the intent is to continue the review for all other Institutions, in light of the Strategic Plan. To that end, the Strategic Plan includes action to re-engineer these entities.

2.3 The Stakeholders of the Community

The peoples who reside within the Member States of the Caribbean Community are to be regarded as the key stakeholders in the Community, as the work of regional integration touches the lives of every citizen, resident and visitor. Other stakeholders include a wide range of national, regional and international institutions and bodies that shape and implement regional

⁷ TCL v. CARICOM [2009] CCJ 4 (OJ), para 43

policy, mobilise resources, enable functional cooperation between Member States, including the Organs and Institutions of the Community, as well as external partners such IDPs.

Specifically, CARICOM's stakeholders include:

Stakeholders

- ⦿ Peoples of the Community - Men, Women, Youth, the Elderly, the Differently-abled.
- ⦿ Members of Parliament.
- ⦿ The Private Sector.
- ⦿ Civil Society Organisations, for example, Professional Associations and Bodies; Non-Governmental Organisations (NGOs); Community-Based Organisations; Faith-Based Organisations; and the Mass Media.
- ⦿ Labour representatives.
- ⦿ Regional Universities/Tertiary Institutions.
- ⦿ International Development Partners.

A critical group among the range of stakeholders are the 'Key Actors' which are those entities that directly contribute to regional integration and the CARICOM agenda through their work.

These Key Actors are:

- ⦿ Regional Governments (Member States and Associate Members).
- ⦿ Government Ministries and Public Agencies in Member States.
- ⦿ CARICOM Organs and Bodies.
- ⦿ CARICOM Institutions and Associate Institutions.

A brief description of these groups follows.

1. **Peoples of the Community**

The peoples of the Community are to be seen as beneficiaries, as well as the architects and implementers of the Vision that they desire for the Community.

2. **Members of Parliament**

Parliamentarians including the Opposition parties, have a key role to play in furthering the integration process in terms of bi-partisan support for policies and legislation. As a result, non-partisan ‘buy in’ to regional integration and the CARICOM agenda is important.

3. **The Private Sector (Regional, National, SME, Employer Associations, etc.)**

The business community is concerned with issues related to employment, productivity, competitiveness, innovation, entrepreneurship and profitability. In that regard, this group of stakeholders is essential for activating and ultimately realizing the goals of the Community as it relates to economic development.

4. **Civil Society Organisations**

Civil Society is defined as the range of non-state entities that will partner with Governments and CARICOM Institutions in regional development. In that regard, there are a range of regional Organisations representing NGOs, churches, and others.

5. **Labour Representatives**

Labour representatives are vital for ensuring that economic development occurs while upholding the rights of workers. Moreover, these Organisations are important ‘gatekeepers’ as it relates to the development of a skilled, competitive and productive regional workforce, able to meet current and future demands.

6. **Regional Universities/Tertiary Institutions**

Tertiary institutions in the Region have, and must continue to play their role in ensuring the development of the human resource of the Community both technically and socially. The regional campuses have been a point of contact for the people of the Community with resultant, sustained personal and business links produced over time. In addition, the Universities have undertaken critical research and developed expertise that has been essential for moving the regional integration project forward.

7. **International Development Partners**

The IDPs are, and will remain, vital to the development within the Region. IDPs comprise Third States, as well as international/hemispheric organisations/institutions. The Partners have been key funders for a range of regional integration programmes, as well as a source for technical expertise and experiential knowledge.

8. **Regional Governments as Member States and Associate Members**

The Heads of Governments, though supported by various other stakeholders, are ultimately accountable to the peoples of the Community for achieving the goals of regional integration.

9. **Government Ministries and Public Agencies**

Government Ministries and Public Agencies in Member States and Associate Members are the policy and administrative conduits for managing the regional integration process. Examples of key Ministries are the Ministries of Foreign Affairs, Trade, Finance, Health, Education and National Security.

10. **The Organs and Bodies**

The Organs and Bodies are at Section 2.2.

11. **CARICOM Institutions and Associate Institutions**

A list of Community Institutions and Associate Institutions is provided at Appendix 2.

2.4 The Services of the Community

The range of services of CARICOM - regional public goods - are provided by the key actors within the Community which i) are required under the Treaty, as well as ii) respond to the demands of Member States. These are as follows:

1. **Regional Policy Development and Management** - to create an enabling environment to implement, and achieve the objectives of the RTC;
2. **Community Governance** - Manage effective governance and decision-making arrangements to support implementation of the RTC;
3. **Project/Programme Planning and Management** - to implement and achieve the objectives of the RTC;
4. **Research and Technical Advice** - to support the development of the Community and enable the RTC;

5. **Public Education and Information** - Building awareness of and commitment to regional integration, the CARICOM agenda (purpose, organisation, opportunities and benefits of the Community) and a *Community for All*,
6. **Advocacy** - regionally and international for the concerns and positions of the Member States of the Community (based on a coordinated foreign policy approach);
7. **Coordination/Harmonization** - of legislative and policy environment to enable equitable access to the benefits of regional integration;
8. **Resource Mobilisation** - for the resources to support regional integration;
9. **Capacity Development** - as a form of functional cooperation, for example, leadership development; project development and management of multilateral and national programmes and projects.

Some examples of specific activities undertaken in delivering these services are outlined in **Appendix 3** on the 'Snapshot of Key Achievements of the Community'.

The consultative process found that this range of services remain important for Member States; however, demand for a number of new services has emerged which are outlined at **Chapter 5 (Section 5.3)**.

However, as the services of CARICOM evolve, there is need for agreement among Member States that, guided by the principles of subsidiarity and proportionality, there is a clear distinction of the value added regional public goods that will amplify the benefits of work being undertaken in Member States themselves. This is an important consideration for the Strategic Plan, particularly in light of the need to maximize the benefits of the resources to be used in implementation, and deliver concrete, equitable results.

3.0 STRATEGIC REVIEW AND ANALYSIS

"The unvarnished truth is that our economies need each other to survive and prosper..."

Dr. the Honourable Kenny D. Anthony, Prime Minister of Saint Lucia, February 2013⁸

This Chapter provides an overview of the global and regional context that underscores the challenges and issues facing the Community.

3.1 The Global Context

The complexity of the global economic environment and the major transformations underway in the world economy cannot be ignored by CARICOM States. In the aftermath of the 2008-2009 global financial and economic crisis, the emerging global trends are unmistakable and marked by the differentiated performance of developed and developing countries and their responses thereto. These trends are coinciding with major shifts in geo-political economic dominance, astounding technological changes with implications for trade and production processes, the growing urgency of the climate change agenda, along with new challenges linked to the dynamics of social change.

The post-crisis weak economic recovery in the developed countries when juxtaposed with the slowdown in economic growth, in particular the emerging economies into the foreseeable future, signal a less favourable international context for small developing countries like CARICOM States into much of the next decade or so. Specifically, the global environment will be characterized by flagging international demand, flat commodity prices, the withdrawal of stimulus measures in both developed and developing countries resulting in rising interest rates, in addition to major structural deficiencies and constraints. As a consequence, traditional external resource flows (both private capital and official flows) upon which CARICOM States have become dependent to stimulate the growth process, will continue to dwindle over time.

Amidst an increasingly volatile and unpredictable world economy, a redistribution in the balance of global economic power is becoming apparent, with China likely to become the leading world economy in the coming years, followed by the United States and the major emerging developing economies - India, Brazil, Mexico and Indonesia. These emerging economies led by those in

⁸ Speech on the occasion of the Twenty-Fourth Inter-Sessional Meeting of the Conference of Heads of Government of the Caribbean Community, Port-au-Prince, 18 February 2013

Asia are fast becoming the main drivers of global growth, resulting in significant changes in the distribution of global output and demand in the future which have considerable implications for CARICOM's future trade and investment relations.

Indeed, the shift in geo-political economic dominance has been aided by the transforming effect of scientific innovation and technological change over the last few decades. It is acknowledged that the greatest influence of innovation and technology on the world, is being exerted by information and communication technologies (ICTs), advanced manufacturing and automation technologies, energy and natural resource technologies and healthcare technologies. The dynamic impact of such technological change is driving the reorganisation of production structures and corporate strategies around the world, with critical success factors involving the quality of human capital and access to scientific and innovation networks.

Driven by the transformational effect of ICTs, the lowering of trade barriers and transport costs worldwide, most of global production is now increasingly taking place in what is referred to as "value chains". These global value chains⁹ are distinctive by their close relationship with foreign direct investment, their heavy reliance on trade in intermediate goods, the high import content of exports and the important role of a vast array of services (financial, legal, logistical, design, communications, etc.) delivered via outsourcing to countries with the required competitive/comparative advantage. The integration into global value chains can be extremely beneficial for developing countries but there are some inherent risks relating to a country's position in the production process which have to be managed carefully.

These huge production networks currently being negotiated, have begun to spawn the creation of mega-markets by transforming the face of traditional regional integration processes. The proposed Trans Pacific Partnership (TPP) involving, inter alia, North and Latin America and Asia, the Regional Comprehensive Economic Partnership (RCEP) in Asia, the Trans-Atlantic Trade and Investment Partnership (TTIP) between the United States and the European Union (EU) and the Trade in Services Agreement (TISA) among major industrialized countries and some developing countries, are among initiatives aimed at harmonizing the rules governing the operations of the various production networks. However, they can also be seen as a response to the growing dominance of the emerging economies in world production and trade and their rules could considerably erode the policy space of developing countries like CARICOM States which are outside of these mega-markets.

⁹ It has been estimated by UNCTAD that over 80% of the world's exports of goods and services occur through trade among multi-national enterprises.

This transformation of production and trading strategies is occurring at a time when the process of climate change has emerged as a global issue thus raising issues related to energy generation and usage, as well as the nature of the technologies deployed in the production processes. Evidence of the acceleration in the process of global warming has not resulted in any noticeable efforts to achieve the agreed target of limiting global temperature to a rise of 2 degrees. In the meanwhile, the increased frequency and severity of climatic events, along with the growing incidence of health pandemics and the threat of terrorism and war, are threatening to retard the development gains achieved overtime by developing countries in particular.

3.2 The Regional Context

Given its susceptibility to external shocks, global realities and challenges are either mirrored or heightened in the CARICOM Region. While most developing countries weathered the global financial and economic crisis and were able to record higher growth rates than the developed world, CARICOM States were faced with the reality of persistent low growth rates and crippling external debt. This situation coincided with only a 64% implementation level of the CSME which, with its emphasis on removing dis-economies of scale and creating complementarities, is being established as the mechanism to allow Member States to build economic resilience and respond to the threats posed by the global environment. However, the level of intra-regional trade and production remains below expectation and critical elements of the macro-economic policy coordination agenda have not been sufficiently advanced by CARICOM States.

Member States economic performance is at variance with that of the Region's neighbours in Latin America, as well as other developing countries and has resulted in growing unemployment especially among youth, threats to economic stability and disenchantment of the international community with the economic management of some Member States, in particular, debt and fiscal management. The response of Member States has initially been the adoption of either home-grown or multilateral supported stabilization and structural adjustment programmes which have not yet resulted in sustained growth in those Member States experiencing significant macro-economic imbalances. Revitalizing economic growth is therefore of critical importance to preventing further deterioration in the Region's human development gains and a regional approach is now being promoted to remove significant micro-economic constraints on competitive production.

The redistribution in the balance of global economic power, the shifting priorities of traditional partners along with geo-political changes in neighbouring regions, constitute major challenges as the Region seeks to reposition itself. It is apparent that such repositioning should involve stemming the erosion of CARICOM's diplomatic and economic strength and effective insertion in the major shifts occurring in the world economy - the per capita income convergence process occurring between the emerging developing economies and the developed world, the growing share of developing countries in world trade, foreign direct investment flows and technological capability as well as the global value chain networks and mega-markets.

This repositioning of CARICOM economies is, however, occurring in a highly volatile and uncertain global economic environment as traditional partners in the industrialized world are unlikely to provide the growth push as in the past. Notwithstanding, there is scope for CARICOM States to transform their production structures into endogenous growth drivers, thereby requiring that emphasis be given to macro-economic stability, increasing investment and boosting levels of productivity as a platform for future growth.

The trend towards the creation of value chains as drivers of production and trade, as well as the growth of mega markets, underscore the importance of the regional space in achieving scale economies, enhancing productivity and increasing trade among CARICOM States. Moreover, enhancing participation in global/regional value chains will require that CARICOM States adopt policies which promote sustainability while enhancing the synergies between trade and investment measures; address infrastructural gaps and deficiencies; stimulate the production capability of domestic firms and ensure that the labour force acquires the relevant specialized knowledge and skills.

The strategies to transform the production structures in CARICOM States must also take into account critical social development issues prevailing in the Community. Specifically, the rising levels of youth unemployment existing alongside skill shortages in several key areas are indicative of a mismatch between the output of our education and training systems and that required for economic competitiveness. Robust systems for Labour Market Information and intelligence to both assess skills requirements and inform Member States' education and training systems must therefore be a priority with greater emphasis on science, technology, engineering and mathematics; entrepreneurship education as well as on technical and vocational education and training. The strategic direction must therefore be one which reviews in a holistic manner, the content and focus of our education and training systems and places emphasis on addressing the relevance of the existing structure and content of the curricula at all

levels. In so doing, specific focus should be placed on innovation and creativity; digital literacy, entrepreneurship; issues of gender and inclusiveness; teacher preparation; and the optimum use of resources among others.

However, generating the skills base to support competitive production in CARICOM States can be compromised by the existence of several social issues which threaten to erode the gains achieved in human development in the Region. These include the continuing prevalence of HIV, notwithstanding the decline in the rate of new infections; the high incidence of Non Communicable Diseases (NCDs); obesity; significant levels of poverty especially among women; increasing crime; adolescent pregnancy; drug abuse; violence and injuries; as well as gender-related concerns, such as violence against women and poor participation and performance of males in education. These issues must continue to remain in the forefront of social development strategies in CARICOM.

Additionally, crime and insecurity, which rank high among the principal threats and obstacles to social and economic development in CARICOM, rob societies of creative potential and energies and cause resources to be redirected to non-productive activities. Social development strategies should therefore address the reduction in the incidence of illegal trafficking in drugs and small arms and light weapons; rising crime against persons and property - especially youth on youth and gang violence, criminal deportees, corruption and cybercrime.

Other major threats to the sustainable economic growth and social development in CARICOM Member States are climate change and natural disasters. While the Region is prone to natural hazards, over the last decade there has been increased exposure to these events due to the effects of climate variability and change. These events have affected entire populations causing severe hardship and dislocation. They have also damaged or destroyed critical physical infrastructure such as airports, ports, telecommunications facilities, roads, coastal protection structures, hospitals and schools; and major productive sectors, such as agriculture and tourism. This requires repeated disaster-related expenditure in infrastructure and in the productive sectors. Natural disaster management is therefore of critical importance to the Region.

As it relates to climate change, CARICOM States contribute less than 1% of global greenhouse gas (GHG) emissions but are expected to be among the earliest and most impacted by climate change. These impacts include more frequent weather events; sea level rise which will magnify the impact of storm surges and waves in coastal areas; water shortages; and weakened protective eco-systems like coral reefs and mangroves. Climate change has been described as

an existential threat to small-island and low-lying coastal states. Analysis has shown that the impact of exogenous shocks, such as natural disasters and the global economic and financial crisis, on the economies of most CARICOM States has exacerbated the debt and fiscal challenges they face.

From the analysis in the Scan, a number of critical issues emerged which, together with data from other sources such as the national stakeholder consultations, form the basis for the strategic framework elucidated at Chapter 4 of the Strategic Plan implemented over the planning period to 2019. Generally, the common, core issues from these data sources are as follows:

External to the Region

- Ongoing contagion effects of the global economic crisis.
- Increasing global competitiveness coupled with the growing proliferation of economic groups/blocs as countries seek to consolidate their assets and economic/political influence.
- Limited access to financing for growth and development exacerbated by 'graduation' of the majority of Member States to 'Middle Income' and 'High Income'.
- Climate Change.

Affecting Resilience

- Significant challenges with high debt, low competitiveness, high unemployment, high costs (particularly food imports and energy) and a deteriorating trade balance for the majority of Member States.
- Persistent vulnerability to external economic shocks.
- Low levels of technology penetration, innovation and research and development.
- Weaknesses in air/maritime transport infrastructure and services to facilitate effective intra-regional trade and hassle free movement of people across the Region.

- ⦿ Lack of energy security due to high cost of energy and energy inefficiency.
- ⦿ Effects of climate variability and increasing incidence of natural disasters, which are predicted to worsen in the future.
- ⦿ Limited social cohesion.
- ⦿ Increasing incidence of crime with resultant serious threats to citizen security.
- ⦿ Persistent challenges with youth marginalization, poverty and access to health care.
- ⦿ Constraints on the legal/regulatory environment that restrict growth.

Affecting the CARICOM Identity

- ⦿ Weaknesses in public education, public relations, communications and advocacy, to the extent that the people of the Region are unaware or ambivalent with regard to the work of CARICOM, and the benefits of regional integration.

Affecting Governance

- ⦿ Weakness in the governance 'infrastructure' with a resultant 'implementation deficit'.
- ⦿ Weakness in operations of the Organs and Institutions of CARICOM viz. limited human resources, limits in technology, communication and management systems. The operating 'infrastructure' (e.g. procurement, human resource management, accounting) across Institutions varies which can hinder collaboration and economies of scale.
- ⦿ A proliferation of mandates, unfunded in some instances, creating a work load that is unsustainable for the Secretariat and other implementing agents (e.g. the CARICOM Institutions).
- ⦿ Lack of clarity of roles and responsibilities among the implementing agents across CARICOM (i.e. CCS, Institutions, Member States), limiting opportunities for collaboration and optimizing the use of scarce resources.

- ⦿ Limited engagement with stakeholder groups (youth, private sector, labour, NGO community) in the policy/decision making/governance process.
- ⦿ Inadequate funding of the work of CARICOM.
- ⦿ Weaknesses in monitoring and evaluation, with no system which allows for 'universal' monitoring of the whole CARICOM architecture.

Given the issues outlined above, the Environmental Scan pointed to the need for priority action in a number of areas such as: implementation of the CSME; macroeconomic stabilization; ensuring an enabling business environment for growth; youth development, entrepreneurship and innovation; improved citizen security and health; human capital development; mainstreaming diversity; reduction in environmental vulnerabilities; diversification and development of energy resources; ICT access; strengthening governance; and building the Regional identity.

These key policy issues give context to the Resilience Model and the Strategic Framework elucidated at **Chapter 4** which follows.

SECTION B

⦿ Where Do We Wish To Be?

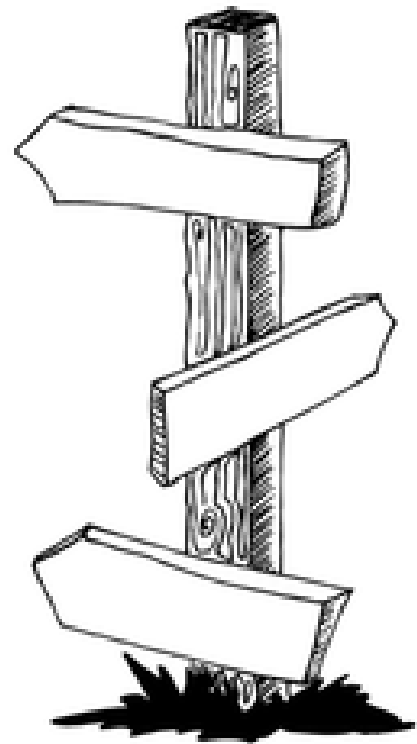

4.0 THE STRATEGIC FRAMEWORK

4.1 CARICOM's Vision, Mission & Core Values

4.1.1 Vision

A Caribbean Community that is integrated, inclusive and resilient; driven by knowledge, excellence, innovation and productivity; a Community where every citizen is secure and has the opportunity to realise his or her potential with guaranteed human rights and social justice; and contributes to, and shares in, its economic, social and cultural prosperity; a Community which is a unified and competitive force in the global arena.¹⁰

4.1.2 Mission

The Community works together to deepen integration and build resilience so as to:

- ① affirm the collective identity and facilitate social cohesion of the people of the Community.
- ② realise our human potential as defined by the Ideal Caribbean Person,¹¹ full employment and full enjoyment of human rights.
- ③ ensure that social and economic justice and the principles of good governance are enshrined in law and embedded in practice.
- ④ systematically reduce poverty, unemployment and social exclusion and their impacts.
- ⑤ mainstream all aspects of sustainable development, including the environmental, economic and social dimensions.
- ⑥ create the environment for innovation, the development and application of technology, productivity and global competitiveness, in which the collective strength of the Region is unleashed.
- ⑦ promote optimum sustainable use of the Region's natural resources on land and in the marine environment, and protect and preserve the health and integrity of the environment.
- ⑧ encourage citizens to willingly accept responsibility to contribute to the welfare of their fellow citizens and to the common good, practice healthy living and lifestyles, respect the rule of law, protect the assets of the Community, and abhor corruption, crime and criminality in all its forms.

¹⁰ Vision Statement developed through consultation among Member States Change Drivers on 9 April 2014

¹¹ See Figure 4, p 54

- ⦿ project 'one voice' on international issues.
- ⦿ increase savings and the flow of investment within the Community.

4.1.3 The Core Values

- ⦿ **Unity/Togetherness** We commit to winning hearts and minds to work towards a robust and inclusive Caribbean Community, able to work together to preserve the gains of regional integration and address the current challenges of economic recovery and growth and sustainable human development. We celebrate the strength of both the shared and diverse aspects of our culture, heritage, and communities.
- ⦿ **Equity** We emphasize the reach of services and benefits to all stakeholders across the Community.
- ⦿ **Integrity** We practice a consistent commitment to honesty, trustworthiness and that which is morally correct in our relationships and operations. We are passionate about what we do and what we believe in - the value of regional integration to enable the development of our Member States.
- ⦿ **People-centeredness** We emphasize the pivotal role of the peoples of the Community at all levels and in all spheres of endeavour to embrace regional integration and the benefits it continues to offer.
- ⦿ **Performance-Driven/Results Focused** We emphasize the importance of targeted results in achieving sectoral/cross sectoral as well as institutional strengthening goals.
We value productivity and we pursue good management practice with planning and implementation of our work and effective monitoring, evaluation and reporting to ensure the desired results are achieved.
- ⦿ **Good Governance** We have an abiding respect for human rights, the rule and law, and take action to ensure social and economic justice for the people of the Community.

We provide proactive, visionary leadership for promoting and reinforcing the spirit and commitment to regional integration, emphasizing transparency, accountability and operational excellence within all organs and institutions in the Community. We rely on research for evidence-based decision-making at all levels, with a systematic approach to monitoring and measuring policy outcomes and impacts.
- ⦿ **Good Environmental Management** We are committed to good environmental management and the protection of the Region's natural assets across all sectors of development; and empowering the peoples of the Community in their preparation for and management of the impacts of natural and man-made hazards and the effects of climate change.

4.2 The Strategic Priorities to 2019

A range of targeted interventions will be applied to address critical gaps over the planning period; for example, to mitigate and overcome the high debt, low growth, vulnerabilities to environmental shocks and the general need for re-balancing intra-regional trade between Member States, as articulated by the DESIRED OUTCOMES (see **Figure 2**) viz,

- Strong Economic Growth and Reduction in Poverty and Unemployment.
- Improved quality of life.
- Reduced environmental vulnerability.
- An integrated Community with Equity for All.

To address the broad development objectives over the planning period to 2019, the set of **integrated Strategic Priorities within the context of a Resilience Model** are proposed (see **Figure 2**) viz,

- Building Economic Resilience.
- Building Social Resilience.
- Building Environmental Resilience.
- Building Technological Resilience.
- Strengthening the CARICOM Identity and Spirit of Community.
- Strengthening Community Governance.

AN INTEGRATED APPROACH

The six priorities are interoperable, each enabling of the other, with the overall outcome of enhanced resilience of the Community. In that regard, the strategic initiatives proposed, as outlined in the Matrix at **Figure 3** which lays out the strategic framework value chain, target key sectors during the planning period, focusing on building resilience through a range of cross-cutting initiatives which take account of the relationships among the six thematic areas, for example, the specific human capacity development or ICT requirements to unleash the growth sectors for building economic resilience; or the actions to strengthen Community governance and institutional arrangements that will engender higher levels of efficacy, responsiveness and results for social and environmental resilience. *Therefore, to ensure economic, social, environmental and technological resilience, a unified Community with strong, efficiency Community instructions are requisite.*

FIGURE 2: SIX INTEGRATED STRATEGIC PRIORITIES OF THE RESILIENCE MODEL





Further, in implementing these six (6) Strategic Priorities, there is ready acknowledgement of critical enablers for success, where specific action must be taken. Also shown in the Matrix at Figure 3, among these enablers is **coordinated foreign policy** - an essential tool for promoting the interests of the Region both internally and externally and mobilising resources for implementation. A second key enabler for success is **research and development and innovation**.

The six point Strategic Framework follows.

FIGURE 3: THE STRATEGIC FRAMEWORK VALUE CHAIN

VISION	A Caribbean Community that is integrated, inclusive and resilient; driven by knowledge, excellence, innovation and productivity; a Community where every citizen is secure and has the opportunity to realise his or her potential with guaranteed human rights and social justice; and contributes to, and shares in, its economic, social and cultural prosperity; a Community which is a unified and competitive force in the global arena.					
ULTIMATE OUTCOMES	<ul style="list-style-type: none"> • Strong Economic Growth and Reduction in Poverty and Unemployment • Improved Quality of Life • Reduced Environmental Vulnerability • An Integrated Community with Equity for All 					
						
INTEGRATED STRATEGIC PRIORITIES	Building Resilience				Strengthening the CARICOM Identity and Spirit of Community	Strengthening Community Governance
	Economic Resilience Stabilisation and Sustainable Economic Growth and Development	Social Resilience - Equitable Human and Social Development	Environmental Resilience	Technological Resilience		
GOALS	<ul style="list-style-type: none"> • To engender sustainable growth of the economies of Member States 	<ul style="list-style-type: none"> • To ensure sustainable human and social development in the Region with reduced levels of poverty and equitable access by vulnerable groups and significant improvement of citizen security by facilitating a safe, just and free community 	<ul style="list-style-type: none"> • To reduce vulnerability to disaster risk and the effects of climate change and ensure effective management of the natural resources across Member States 	<ul style="list-style-type: none"> • To engender innovative, technology-driven economies and societies in the Region. 	<ul style="list-style-type: none"> • To refine and intensify the promotion of the 'CARICOM Identity' that binds the people of Member States together and engenders a sustained sense of belonging. 	<ul style="list-style-type: none"> • To ensure effective and efficient governance arrangements that support good decision-making, successful implementation of the regional agenda and accountability by all actors.
STRATEGIES	ECN 1: Accelerate implementation and use of the CARICOM Single Market and Economy	SOC 1: Advance Human Capital Development: Key Skills, Education Reform and Youth Development	ENV 1: Advance Climate Adaption and Mitigation	TEC1: Develop a Single CARICOM ICT Space	UNY 1: Enhance Public Education, Public Information, Public Relations and Advocacy	GOV 1: Reform of Organs, Bodies and Governance Arrangements to enhance Decision-Making, Implementation and Accountability and Enforcement
	ECN 2: Integrate into the Global Economy	SOC 2: Mainstream inclusiveness in Public Policy: Gender, Persons with Disabilities, Age	ENV 2: Advance Disaster Mitigation and Management	TEC 2: Bring Technology to the People and Transform them to Digital Citizens and Digital Entrepreneurs	UNY 2: Refine and Promote the CARICOM Identity and Civilization	GOV 2: Develop Arrangements for Participatory Governance
	ECN 3: Introduce Measures for Macroeconomic Stabilisation	SOC 3: Advance Initiatives for Health and Wellness	ENV 3: Enhance Management of the Environment and Natural Resources	TEC 3: Strengthen Cyber Security	UNY 3: Facilitate opportunities for the people of the Region to build social and economic relationships	GOV 3: Develop Governance Arrangements for Community Institutions
	ECN 4: Build Competitiveness and Unleash Key Economic Drivers to Transition to Growth	SOC 4: Enhance Citizen Security and Justice		TEC 4: Mobilise Resources and Commitment of Member States to Invest in ICT	UNY 4: Strengthen Relationships among Member States	GOV 4: Strengthen Relationships and Build Partnerships with IDPs
						GOV 5: Develop and Agree on the Desired Governance Arrangements for the Future

						
STRATEGIC OBJECTIVES	<p>To restore confidence in CARICOM economies</p> <p>To reverse negative perceptions about economic management and governance in the Caribbean Community</p> <p>To lay the foundation for innovative resource mobilisation strategy to support the Growth Agenda</p> <p>To engender growth of the economies of Member States</p>	<p>To build the capacity of Caribbean people to create regenerative societies</p> <p>To forge a culture of innovation and entrepreneurship</p> <p>To eliminate the significant wastage occurring in the education systems</p> <p>To ensure that the diverse needs of the people of the Community are understood and met</p> <p>To ensure universal access to basic health services</p> <p>To reduce mortality and morbidity related to NCDs and HIV</p> <p>To disrupt, dismantle and defeat transnational organised crime</p> <p>To enhance human resource capabilities and strengthen regional security systems</p> <p>To improve the economic viability of the Region</p>	<p>To increase the use of clean and renewable energy</p> <p>To build capacity to manage adaptation and mitigation to climate change</p> <p>To enhance resilience to natural disasters</p> <p>To mainstream environmental sustainability into policy, planning and public education and public awareness of sustainable environmental management</p>	<p>To use technology to build a competitive regional economy</p> <p>To create opportunities for the people of the Community to participate actively in the Digital Economy</p> <p>To increase public sector use and citizen adoption of e-government</p> <p>To increase job creation entrepreneurship and new business development in ICT</p> <p>To support the creation of 'Smart' (i.e. digitally enabled) communities</p>	<p>To create internal cohesion, and ownership of, and support for, the work and the goals of the Community</p> <p>To advance the development agenda of the Community</p> <p>To build and foster a positive image of the Community</p> <p>To position CARICOM as a brand in the regional and international community</p> <p>To accelerate the integration of the people of the Community</p> <p>To establish and maintain productive engagements and partnerships with the stakeholders</p> <p>To engender commitment, pride and a sense of belonging among CARICOM citizens</p> <p>To increase awareness and appreciation of CARICOM Member States among the people of the Community</p> <p>To create viable social and economic relationships among the people of the Community</p>	<p>To enhance the practice of effective governance in the Community</p> <p>To improve the efficiency of Community organisations</p> <p>To improve the rate of implementation of Community decisions and the CARICOM agenda</p>
						
ENABLING STRATEGIC PRIORITIES	<p>1. Coordinated Foreign and External Economic Relations: These policies are integral to achieving CARICOM's Strategic Objectives, Integrated Strategic Priorities and Ultimate Outcomes. They will also contribute to CARICOM being an active player in the international environment. In this regard action will be taken to:</p> <ul style="list-style-type: none"> ▪ Promote and defend the interest of CARICOM ▪ Develop strategic alliances in the changing international environment ▪ Maintain and strengthen relations with traditional partners ▪ Strengthen the collaboration and cooperation with third countries and groups ▪ Secure the recognition, acceptance and implementation of CARICOM positions and initiatives ▪ Mobilise resources externally to address CARICOM'S priorities <p>2. Research and Development and Innovation - To mainstream R & D and Innovation on the work of CARICOM viz</p> <ul style="list-style-type: none"> ▪ Consistent use of an evidenced-based approach ▪ Advocacy for resources (state and private sector) to finance R & D in business development ▪ Facilitate an enabling legislative environment for R & D and Innovation ▪ Identify and promote opportunities for functional cooperation in R & D and Innovation ▪ Advocate for national school-based programmes that drive, enable and reward R & D and Innovation 					

4.2.1 Building Economic Resilience - Stabilisation and Sustainable Economic Growth and Development

4.2.1.1 Introduction

Current analyses predict that difficult economic times may persist for several Member States over the planning period to 2019. Because of this and the Region's other vulnerabilities, Building Economic Resilience will be primary among the six Strategic Priorities, enabled by all others. This Priority will focus on creating an enabling environment for stabilization and transitioning to growth of the economies of Member States viz,

- ⦿ Accelerating implementation and use of the CARICOM Single Market and Economy.
- ⦿ Integration into the Global Economy.
- ⦿ Introducing Measures for Macroeconomic Stabilisation.
- ⦿ Building Competitiveness and Unleashing Key Economic Drivers to Transition to Growth.

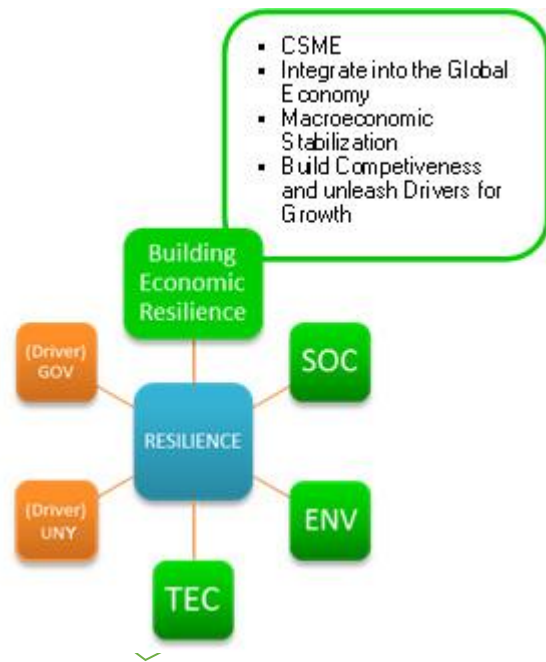

4.2.1.2 Goal

- ⦿ To engender sustainable growth of the economies of Member States.

4.2.1.3 Strategies

1. **ECN 1- Accelerate Implementation and Use of the CARICOM Single Market and Economy** - The fundamental rationale for implementing the CSME, is to achieve sustained economic development based on international competitiveness and coordinated economic policies and enhanced trade and economic relations with Third States. The CSME is intended to, *inter alia*, provide larger market opportunities; take advantage of greater economies of scale; stimulate increased competitiveness; and increase opportunities for investment. This strategy will address:

- (a) Full implementation of the five regimes¹² under the CSM (e.g. advancing free movement of Community Nationals and free movement of Skilled Community Nationals in keeping with Articles 45 and 46 of the Revised Treaty; with a focus on youth and emerging skills) and advancing the macro-economic policy agenda to support production, growth and development including:
 - i. Market integration and removing barriers and gaining compliance across all Member States with the various arrangements;
 - ii. Harmonisation of the legislative and regulatory environment to enhance/enable regional integration as per Article 74 of the Revised Treaty;
 - iii. Advancement of other areas under Article 239 e.g. electronic commerce;
 - iv. Macroeconomic convergence and policy coordination and harmonization;
- (b) Address the constraints to intra-regional trade with a view to increasing the level of intra-CARICOM trade beyond the current level which presently accounts for between 13% to 16% of total intra-regional trade;
- (c) Promotion for increased utilization of CSME arrangements by target beneficiaries;
- (d) Fuller participation by the private sector especially for production integration.

2. **ECN 2 - Integrate into the Global Economy** (enhanced Trade and Investment);

Position the Region to meet the challenges and opportunities of the changing global environment and to achieve one of the objectives articulated in the Revised Treaty, namely the expansion of trade and economic relations with Third States. The strategies will therefore be to:

- (a) Attract foreign direct investment through promotion of joint ventures and public private partnerships;

¹² The five regimes viz. free movement of skills, free movement of goods, free movement of services, movement of capital and rights of establishment

- (b) Address the conditions/factors for creating an enabling environment to facilitate the private sector taking advantage of the opportunities presented under the Trade Agreements which CARICOM has concluded with third countries, as well as to expand trade generally to all countries.
3. **ECN 3 - Introduce Measures for Macroeconomic Stabilisation** - which will include addressing financial stability and debt management in Member States and establishing an advisory mechanism for Member States on debt management - as proposed by the CARICOM Commission on the Economy.

The CARICOM Commission on the Economy in its Preliminary Report (February 2014) has proposed Immediate-term and Medium-term programme of action as follows: **Immediate-term:** Macro-economic stability, specifically fiscal sustainability and the management of the domestic and external debt; promoting a conducive environment for private sector growth and development; formulation of a proactive resource mobilisation strategy. **Medium-term:** defining a production integration model for the Community with supportive frameworks for trade facilitation and finance; and addressing 'labour market issues' within the context of the CARICOM production integration model; determining a regional public private partnership model along with a set of regional public goods in respect of the targeted sectors.

4. **ECN 4 - Build Competitiveness and Unleash Key Economic Drivers to Transition to Growth and Generate Employment** - Enabling a Competitive Business Environment within the Region through promoting and enabling research and development, innovation, ICT and entrepreneurship (special emphasis on youth entrepreneurship); promoting productivity and the social dimensions of labour in collaboration with labour representatives; and stimulating and creating an enabling environment for the private sector, particularly the regulatory environment to enhance intra-regional and external trade,¹³ for example:
- (a) Harmonization and simplification of business regulations and processes in Member States and in the Community, including advancing work on the Single

¹³ Specific initiatives within this Strategy will adjust based on the work of the CARICOM Commission on the Economy

Jurisdiction for the Registration and Incorporation of Companies (within the CSME arrangements);

- (b) Establishing a framework for engagement and partnership with the private sector.

Unleash Key Economic Growth Drivers viz,

- (a) **Creative, Manufacturing and Services Industries** - with an emphasis on Tourism Services in the immediate term (initiatives recommended by the CARICOM Commission on the Economy). Also this strategy will build on the preparation of strategic plans for the following service industry sectors: Tourism Services, Financial Services, ICT Services, Professional Services, Construction Services, Education Services, Health and Wellness Services and Cultural, Entertainment and Sporting Services;
- (b) **Leveraging the regional integration arrangements to develop resource-based (natural resource and value added) products and promote production integration;**
- (c) **Agriculture (Food and Nutrition Security and Export Development)** - positioning the regional agricultural and fisheries sector as one economic space for growth and export development and enable food and nutrition security taking in account existing strategies to remove key binding constraints and to deliver on the Common Agriculture Policy, the Regional Food and Nutrition Policy, the Common Fisheries Policy viz,
 - i. Establishing a system of regional indicators for Agriculture targeted at reducing the food import bill within specified time frames. Select commodities based on their potential competitiveness and contribution to import substitution, exports, alleviation of food security risks, production integration, and increased contribution to economic development and GDP;
 - ii. Advancing initiatives for exports through promoting an enabling environment in Member States for attracting investment in small and large scale agri-food initiatives, while encouraging entrepreneurship among youth, women and small farmers (linked to building Social Resilience);
 - iii. Developing a fully integrated and harmonized Regional Agricultural Health and Food Safety System;

- iv. Advancing initiatives for sustainable expansion and intensification of fish production through responsible aquaculture development in both coastal waters and inland, particularly in the countries with large land masses and fresh water resources such as Guyana, Belize, Suriname, Haiti, Jamaica and Trinidad and Tobago;
 - v. Stabilize and gradually enhance the contribution of fish catches from marine and inland waters, while ensuring long-term sustainability through improved, cooperative management and conservation measures using an ecosystem approach to fisheries, as well as through adoption of proper legal, regulatory and institutional measures, and technological innovations, to develop underutilized and unutilized species, address overfishing, and eradicate illegal, unreported and unregulated (IUU) fishing in the CARICOM Member States;
 - vi. Developing a risk mitigation framework to reduce the impact of climate change;
 - vii. Develop programs to provide alternatives for the traditional agriculture;
- (d) **Developing the Air/Maritime Transport Infrastructure and Services** - to improve accessibility and mobility for people and goods; enhance competitiveness at a global level; improve access to traditional and non-traditional markets; improve maritime and air transport reliability, efficiency, safety and security; establish a single/integrated airspace; harmonize the regulatory, institutional and administrative environment. In that regard, specific interventions will include:
- i. Developing the framework for effective delivery of air and maritime transportation, including implementation of the Aid for Trade Strategy for Modernization of Freight Logistics, Maritime Transport, Trade Facilitation and Maritime Cargo and Passenger Services;
 - ii. Addressing cost and sustainability of transportation in the Region;
 - iii. Addressing ease of travel in the Region.

Initiatives over the Plan period to 2019 will be guided by the programme of action developed by the Regional Transport Commission.

- (e) **Energy Efficiency, Diversification and Cost Reduction** - Focused on optimizing existing assets, reducing the high cost of energy inputs (particularly in production) through enhanced functional cooperation, and development of alternative energy to meet CARICOM's target of 20% by 2017 for the contribution of renewable

energy to the total electricity supply mix. Therefore this strategy will address energy efficiency across all sectors, development and use of renewable energy, legislative and market reform to allow for access of renewable energy to the electricity network, building awareness and capacity within Member States, and facilitating public private partnership in energy development and build on the CARICOM Energy Policy adopted in 2013;

- (f) **ICT** - Developing the ICT Sector and promoting ICT in public sector management, business development and economic growth (in alignment with the Regional Digital Development Strategy at Strategic Priority 4 - Building Technological Resilience);
- (g) **Resource Mobilisation**¹⁴ - Developing innovative approaches to resource mobilisation to support economic growth including Foreign Direct Investment, public-private partnership, new sources of financing and an enhanced CARICOM Development Fund.

4.2.1.4 Key Considerations

1. **The CSME** will remain a primary platform for building international competitiveness and economic resilience for the Region. A critical success factor is to create an enabling regional business environment and address significant cost factors to production, such as transportation and energy.
2. Specific actions of the strategies outlined above will be developed over the Plan period through the work of various **Commissions/working groups** viz. the CARICOM Commission on the Economy, the ICT Cluster, and the Regional Transport Commission.
3. **Private sector** participation and leadership are vital for building resilience. Initiatives to stimulate and engage the private sector underpins the four resilience priorities and are linked with those initiatives to engage the private sector in the governance and decision making of the Community (Strategic Priority 6).

¹⁴ Specific initiatives to be developed over the Plan period through the CARICOM Commission on the Economy

4. **Information and Communication Technologies** is fundamental to building resilience and in that regard underpin the achieving of strategies related to economic, social and environmental resilience. To that end, there are focused ICT initiatives that are recommended in these priority areas, e.g. development of a regional labour market information system (e.g. to facilitate free movement of skills), an improved and harmonised energy information system, and a regional agricultural market information system linking CSME initiatives.
5. **Developing a supporting/enabling legislative/regulatory environment** is also essential for building resilience. One area of special focus will be the harmonisation of legislation, standards and procedures to facilitate the specific initiatives recommended.
6. **Human Resource Development** is another critical success factor in building resilience. Specific initiatives are proposed to facilitate the initiatives recommended, with a special focus on youth e.g. skills for accessing and optimising business opportunities created through regional integration efforts; developing skills for new and existing productive sectors; strategic use of specialist training facilities, for example, the Caribbean Maritime Institute; continuous training and development of public officers; and developing specialists skills in key areas such as climate change, security, public sector management (legal and managerial), and ICT. Further, human resource development initiatives should be linked to advancing the implementation of Articles 45 and 46 of the RTC with a view to ensuring that the Region has access to skills needed for the development of target sectors and industries.
7. **Research** and dialogue will be at the forefront of efforts to become more proactive in meeting the economic development needs of Member States. As an example, the CARICOM Commission on the Economy will continue work to define the production integration model for the Community.¹⁵

¹⁵ Preliminary Report of the CARICOM Commission on the Economy 2014

4.2.2 Building Social Resilience – Equitable Human and Social Development

4.2.2.1 Introduction

Building social resilience complements, and is complemented by, economic resilience. The Region's efforts to improve the quality of life of its peoples will be advanced through the following strategies in the planning period:

- ⦿ Advancing Human Capital Development: Key Skills, Education Reform and Youth Development.
- ⦿ Mainstreaming Inclusiveness in Public Policy.
- ⦿ Advancing Initiatives for Health and Wellness.
- ⦿ Enhancing Citizen Security and Justice.

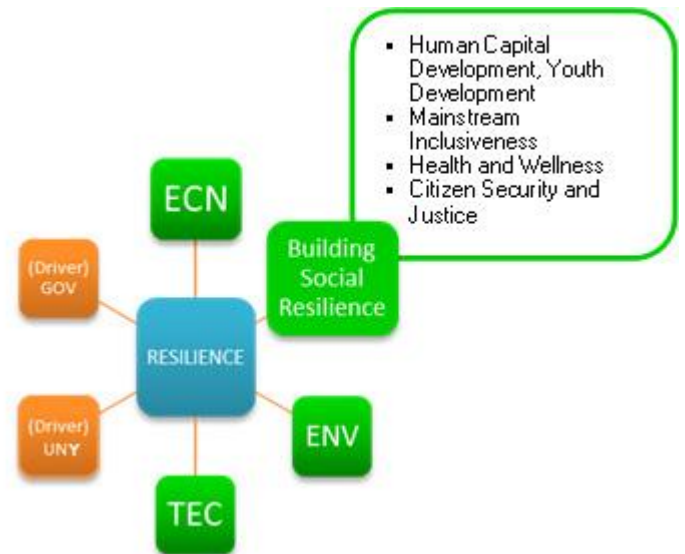

4.2.2.2 Goal

- ⦿ To ensure sustainable human and social development in the Region, with reduced levels of poverty and equitable access by vulnerable groups and significant improvement of citizen security by facilitating a safe, just and free Community.

4.2.2.3 Strategies

1. **SOC 1- Advance Human Capital Development: Key Skills, Education Reform and Youth Development** - This Strategy will address the following:
 - (a) Develop a holistic Regional Education and Human Resource Development Strategy to 2030 which would focus inter alia, on enabling knowledge based growth through demand led education and training at all levels; addressing the linkages between culture, sport and education; the social and personal skills necessary for the 21st Century economy and society; leveraging new technologies; appropriate teacher development, leadership at all levels of the

System; quality and equity imperatives; and financing, efficiency and sustainability¹⁶;

- (b) Facilitating training and development to build capacity in key skills, and the movement of skills identified as required for successful implementation of regional integration initiatives and advancement of the CARICOM agenda (for example, for implementation of strategies in the Strategic Plan);
 - (c) Youth development initiatives to address youth entrepreneurship, employment, multilingualism, healthy lifestyles, leadership skills, citizenship, regional identity and preparation for participation in governance.
2. **SOC 2 - Mainstream Inclusiveness in Public Policy** - Focused on furthering mainstreaming inclusiveness, Gender, Persons with Disabilities, Age, in the work of the public sector in Member States.¹⁷
3. **SOC 3 - Advance Initiatives for Health and Wellness** - Focused on i) working towards the development of a regional health insurance system¹⁸ with a basic package of services¹⁹ that includes Non-Communicable Diseases (NCDs), HIV/AIDS treatment services, and basic mental health screening; and which is based on a costing of services; ii) health education and prevention initiatives re NCDs and HIV/AIDS; iii) regional management of pandemics; and iv) creating an enabling environment and facilitating inter-sectoral actions for improved health and wellness across the Community.

¹⁶ Decision of Heads of Government at the 25th Inter-Sessional Meeting, March 2014

¹⁷ "Mainstreaming" will involve a range of initiatives to build the capacity of the public sector officers to conduct requisite analyses, collect and use disaggregated information, and integrate gender/disability/aging sensitive approaches in policy, planning, implementation, budgeting and monitoring

¹⁸ Under active consideration of the COHSOD. Follows on the mandate of Heads from the July 2013 Meeting to look at financing of health care

¹⁹ Basic package may include - primary care services, prevention, treatment and care for NCDs, HIV, mental health

4. **SOC 4 - Enhance Citizen Security and Justice** - The strategy will involve:
- (a) **Disrupting, Dismantling and Defeating Transnational Organised Crime** viz. the development of mechanisms to identify and facilitate the tracing of criminal assets and to strengthen the Region's capacity in investigation methods and techniques in the field of asset recovery;
 - (b) **Enhancing Human Resource Capabilities and Strengthening Regional Security Systems** - In the Plan period, action will be taken to develop training programmes for law enforcement and security officials, including train-the-trainers and to seek to commence the establishment and expansion of regional Centres of Excellence for training and will seek to standardise training and operating procedures of law enforcement agencies in priority areas;
 - (c) **Strengthening CARICOM's Resilience to Cybercrime** - focusing on strengthening regional human resource and infrastructural capacity to deal with cyber security threats. This will be done through a coordinated regional approach aimed at enhancing capacities and an enabling policy and legislative environment. The first step will be a CARICOM Cyber Security Strategy followed by training of ICT professionals. Prosecutors, judges, investigators, security and intelligence analysts, policy analysts, security operations personnel and network administrators. It will also explore the resources needed to develop equipment and infrastructure for the establishment of a CARICOM Cyber Crime Centre, as well as incorporate the establishment of a central CARICOM Emergency Response Team to provide support to CARICOM Member States in the investigation and prosecution of cybercrimes;
 - (d) **Strengthening CARICOM Borders and Enhance Maritime and Airspace Awareness** - This will be done primarily through the expansion of the existing Advance Passenger Information System (APIS) to all CARICOM Member States and the establishment of the Advance Cargo Information System (ACIS) in addition to the training of border security personnel;

- (e) **Increasing Trans-border Intelligence and Information Sharing - This will focus on enhancing** information sharing with foreign partners and closer cooperation among intelligence, law enforcement, and other applicable agencies regionally. Main areas of focus would include the promotion and utilization of a network of Liaison Officers and national points of contact (NPCs) in Member States and with the establishment of National Joint Operational Centres which will serve as a national intelligence focal point for information and communication, incorporating and maximizing the use of existing resources of law enforcement, military, coast guard, customs, immigration, financial units, intelligence and civilian organisations;
- (f) **Pursuing Functional Cooperative Security Engagements to tackle and manage shared risks and threats.** This will strengthen cooperation with international law enforcement and security agencies to facilitate cross border cooperation;
- (g) **Deepening Crime Prevention Initiatives and Programmes** - the strategy will involve the rollout of crime prevention initiatives across the Region, in collaboration with Member States. Programmes will target children/youth in schools and communities and will focus on addressing the major risk factors for crime and violence at the individual, family and community levels. It will also address capacity building of institutions such as schools, faith based organisations, youth groups, and others to address building of resilience in 'at risk' youths and vulnerable communities. The CARICOM Social Development and Crime Prevention Strategy provides a template for addressing these issues;
- (h) **Facilitating Justice Reform** - modernized and efficient court systems and procedures, including the use of technology to facilitate case management and the efficient filing, disposition and tracking of court matters; reduction of backlog in the judicial system; training and retaining skilled personnel in the justice system - judges, lawyers, police officers, investigators and counselors; structured cross-border/regional systems to bolster national and regional efforts in justice protection, mutual legal assistance, law enforcement, enforcement of judgements; and improved access by the legal profession and the public to legislation, case-law and other legal information.

4.2.2.4 Key Considerations

1. **Determining the critical skills needed** for undertaking specific interventions, projects and programmes towards building resilience will be critical going forward over the Plan period. Specific action must be taken in collaboration with regional universities and tertiary institutions to close gaps, for example, public sector management, ICT, energy, fiscal management, business development and investment (including language skills) and public health.
2. **The leadership of youth** is vital to ensuring the relevance and sustainability of initiatives for building resilience. Adopting appropriate mechanisms, youth representatives must be at the forefront of planning and implementation.
3. **The role of leadership** is vital to building social resilience, social cohesion and the moral fabric of the Community. In particular, the enhanced leadership role of Faith Based Organisations and institutions of learning is emphasized.
4. **Integrated policy management** is fundamental to building resilience. Bearing in mind the interoperable aspects of economic and social resilience, for example linking nutrition with agriculture development; fora that bring together stakeholders in both sectors must be undertaken, for example, joint meetings of the COTED and COHSOD.
5. Over the Plan period, steps will be taken to bring alignment between the Strategic Plan and the **Post 2015 Development Agenda and Sustainable Development Goals**. In the period leading up to the development of the Agenda, a coordinated foreign policy approach will be an important tool to ensure the special needs of CARICOM and SIDS are central to the development agenda.

4.2.3 Building Environmental Resilience

4.2.3.1 Introduction

Every Member State within CARICOM is vulnerable to the effects of climate change and poor environmental management. Climate change is a significant threat to Member States within the Community and the Caribbean Sea itself. The Region is prone to an increased incidence of severe weather, coastal zone erosion, effects on flora, fauna and agriculture and other concerns. In that regard, CARICOM will strongly advocate for the Region's special needs and considerations as it relates to building environmental resilience, in the context of the global discourse on SIDS (in 2014) and the UN Post 2015 Development Agenda and Sustainable Development Goals.

Further, over the Plan period, the following strategic initiatives will be pursued:

- ⦿ Advancing Climate Adaptation and Mitigation.
- ⦿ Advancing Disaster Mitigation and Management.
- ⦿ Enhancing Management of the Environment and Natural Resources.

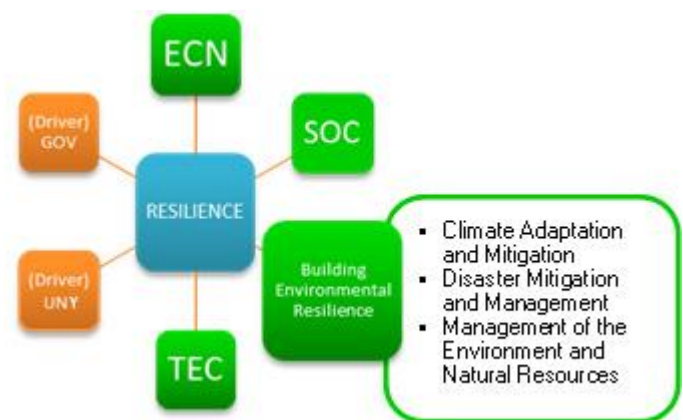

4.2.3.2 Goal

- ⦿ To reduce vulnerability to disaster risk and the effects of climate change and ensure effective management of the natural resources across Member States.

4.2.3.3 Strategies

1. **ENV 1 - Advance Climate Adaptation and Mitigation** viz.
 - (a) Ensure the periodic updating of the Regional Framework for Achieving Development Resilient to Climate Change and the Implementation Plan 2011 - 2021 to guarantee continued currency with national and regional development imperatives;

- (b) Pursue the full operationalisation of the Implementation Plan and secure complete integration of its elements into national and regional development agendas;
- (c) Prepare Member States to be in a state of climate finance readiness;
- (d) Support the development of a compendium of projects of Member States for action by the CCCCC and its partners to leverage the financing to support implementation of national resilience-building initiatives;
- (e) Promote actions to derive benefits from the international response to climate change.

2. **ENV 2 - Advance Disaster Mitigation and Management** - Focusing on a comprehensive approach to disaster management which involves the management of all hazards, throughout all phases of the disaster management cycle and involving all peoples and sectors of the economy. This integrated risk management approach will center on:

- (a) Integrating Comprehensive Disaster Management (CDM) into national policies, strategies and legislation;
- (b) Strengthening national and regional institutional capacities for effective support of CDM implementation, monitoring and evaluation (including mobilisation of resources);
- (c) Enhancing preparedness and capacity for effective and efficient coordination of response and recovery at the national and regional levels (including public awareness and education);
- (d) Building an infrastructure for fact-based policy and decision-making;
- (e) Improving integrated risk management at the sectoral level for key priority sectors.

3. **ENV 3 - Enhance Management of the Environment and Natural Resources** - Legal and Regulatory reform to improve land use planning and management; pollution prevention and control; waste management; building national and institutional capacities to conduct and use environmental and social impact assessments (including climate change screening/proofing); promoting energy efficiency and renewable energy options (linked to Climate Adaption interventions above); promoting sustainable use and management of biodiversity; promoting integrated Coastal Zone Management; promoting conservation, management and sustainable use of the marine living and forest resources; and enhancing regional capacity to address ocean governance issues associated with, inter alia, proliferation of alien and exotic species, marine litter and biodiversity beyond national jurisdiction.

4.2.3.4 Key Considerations

1. **Building capacity of critical skills** will remain a focus over the Plan period. Gaps in expertise still exist in Member States; for example, as it relates to change adaption, natural resource and environmental management in public sector and resource mobilisation. These gaps will be addressed through training and development as well as improved transfer of skills from Community Institutions.
2. Climate change and environmental and natural resource management present a significant opportunity for the Region to access resources for development. Building capacity for, and adopting a coordinated approach to, **resource mobilisation** as a Region, will be important in the Plan period.
3. The Region needs access to appropriate technologies that will enhance climate change adaptation, resource efficiency and measuring and monitoring of environmental changes. The issue of transfer of, and access to, affordable technology is critical in this regard.

4.2.4 Building Technological Resilience

4.2.4.1 Introduction

The importance of building technological resilience to ensure that CARICOM Member States are innovative and globally competitive is well embraced by all stakeholders in the Region. Over the Plan period, bearing in mind the differing levels of readiness of Member States, steps will be taken to develop a CARICOM Digital Economy within the framework of a CARICOM Digital Agenda 2025.

In pursuit of same, focused attention will be given to:

- ⦿ Developing a Single CARICOM ICT Space.
- ⦿ Bringing Technology to the People and transforming them to Digital Citizens and Digital Entrepreneurs.
- ⦿ Strengthening Cyber Security.
- ⦿ Mobilising resources and commitment of Member States to invest in ICT.



4.2.4.2 Goal

- ⦿ To engender innovative, technology-driven economies and societies in the Region.

4.2.4.3 Strategies

1. **TEC 1 - Develop a Single CARICOM ICT Space** - to enhance the market and environment for investment and production thereby improving efficiencies and exploiting opportunities with respect to telecoms/connectivity such as broadband development, lowering costs for consumers (e.g. data, roaming charges), improving the legal/regulatory framework, spectrum management, deepening use of technology to support research and innovation, stimulating new ICT business.

2. **TEC 2 - Bring Technology to the People and Transform them to Digital Citizens and Digital Entrepreneurs** - This will focus on:
 - (a) Bringing Technology to the people viz. e-government and m-Government; Open data to stimulate innovation; Development of sector specific applications e.g. Tourism, Health, Cultural Industries;
 - (b) Creating Digital Citizens and Entrepreneurs: Capability and awareness building, paths to professional development; e-inclusion (access to all), strengthening of financing solutions (e.g. e-payments, digital wallets), re-skilling of the society.
3. **TEC 3 - Strengthen Cyber Security** (linked with Social Resilience - Citizen Security) - This will focus on initiatives to fully secure the single ICT space.
4. **TEC 4 - Mobilise Resources and Commitment of Member States to Invest in ICT** - To ensure adequate resources for ICT development including commitment of the Region's governments, other sources (national, regional and international), public-private-people partnerships, engagement of the diaspora, other initiatives proposed by the Commission on the Economy.

4.2.4.4 Key Considerations

1. There are a range of **national and regional initiatives already underway** upon which the ICT strategies will build. For example, CSME, CKLN/Caribbean Research and Education Network (C@ribNET), Regional Digital Development Strategy (RDDS), ICT in Education, Aid for Trade Strategy, ICT Services Strategy.
2. **Adequate and timely resources** are needed for success - financial, technical and human. A determination of these resources, including key skills, will require a firm commitment among stakeholders to ensure that they are made available.
3. **Member States are at differing levels of readiness** as it relates to developing the digital economy. This will be taken into account, with opportunities for collaboration and cooperation between Member States to ensure that all will benefit for ICT development.

4. **Partnerships between the public sector, private sector and civil society** are essential for ensuring equity of access to all and for overall success in building technological resilience. Appropriate incentives would be needed to enable investment by the private sector and development of ICT businesses.
5. Parity of attention will be given to ensuring there is an **enabling environment for ICT** development, taking account of the need to address exiting market constraints, infrastructure needs and the legal/regulatory framework at the regional and national levels.
6. Opportunities for collaboration and cooperation between Member States should be promoted and facilitated.
7. **A research agenda** will emerge as the planning process for the Digital Economy continues, which would need the support of both private and public research entities, in particular, the Region's universities and tertiary institutions.

4.2.5 Strengthening the CARICOM Identity and Spirit of Community

4.2.5.1 Introduction

To recapture and strengthen the spirit of Community as envisioned, four primary strategies are proposed:

- ④ Undertaking a comprehensive public education, public information, public relations and advocacy programme that positions CARICOM, the regional integration movement, in the hearts and minds of the people of the Community and in so doing, engender a sense of belonging and commitment to the Region.
- ④ Refining and promoting the CARICOM Identity and Civilization.
- ④ Facilitating opportunities for the people of the Region to build social and economic Relationships.
- ④ Strengthening relationships among Member States.

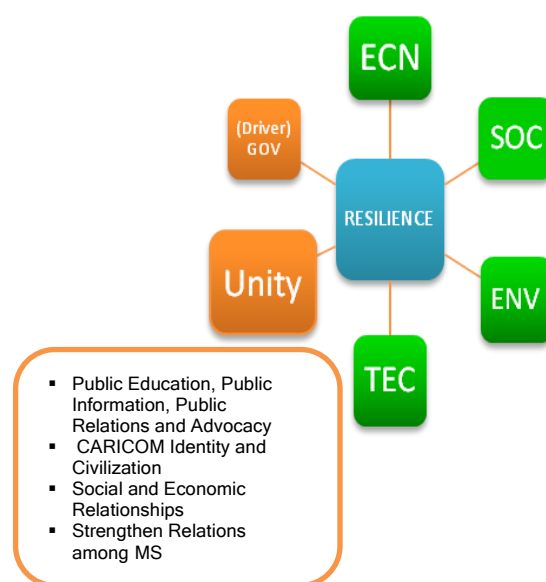

4.2.5.2 Goal - Strengthening the CARICOM Identity (UNY)

- ④ To refine and intensify the promotion of the 'CARICOM Identity' that binds the people of Member States together and engenders a sustained sense of belonging.

4.2.5.3 Strategies

1. **UNY 1 - Enhance Public Education, Public Information, Public Relations and Advocacy -**
Strong, consistent, effective communications is the 'lifeblood' of any community, more so regional communities. In that regard, over the Plan period, CARICOM will seek to attain operational excellence in this area. The proposed four-tier Communications Strategy being finalized by the CCS, will act as a framework for enhanced communications among all the CARICOM entities - Organs, Bodies, Institutions and Member States. The Strategy will address both 'internal' communications, strengthening the communications among CARICOM entities, as well as external communications with people of the Community and other stakeholders. Strengthening external communications over the Plan period, is likely to bring significant returns with respect to stakeholder engagement, building commitment for regional integration and the CARICOM agenda, building a strong, vibrant 'Community for all', and establishing CARICOM as an 'integrated force in the global arena'. This strategy will address:
 - (a) Building an efficient, multilingual communications network;
 - (b) Promoting regional integration, the work/services/opportunities of the Community, the benefits of CARICOM;
 - (c) Optimizing opportunities to showcase the Region - its people's, enterprise, achievements, assets;
 - (d) Positioning CARICOM at the forefront of global issues affecting the Region and Member States;
 - (e) Strengthening the CARICOM 'brand' and perception among the people of the Region and internationally;

- (f) Promoting the symbols of the Community to engender a sense of belonging and commitment to the Region;
 - (g) Engendering and maintaining public awareness and interest in the regional integration agenda.
2. **UNY 2 - Refine and Promote the CARICOM Identity and Civilization** - this strategy will focus on building the strong sense of Community unity and pride that is essential for regional integration and the CARICOM Agenda. This will involve facilitating dialogue across the Community; refine and then promote the “CARICOM Civilization”; promoting the Ideal Caribbean Person (See **Figure 4**); identifying appropriate ‘symbols’ of CARICOM around which to reignite pride, the spirit of integration e.g. the CARICOM Song, CARICOM Day, marquee events, sports (e.g. West Indies Cricket); redefining and reorienting the CARICOM related curriculum in schools; and integration of the Diaspora.
 3. **UNY 3 - Facilitate Opportunities for the People of the Region to Build Social and Economic Relationships** - through professional, academic and cultural exchanges, e.g. apprenticeship and on the job training opportunities for youth, worker exchange programmes, student exchange programmes, CARICOM Youth Volunteer Programme; organized tours and greater promotion of intra-regional travel and tourism. A major enabler of this strategy will be initiatives to ensure ease of travel/hassle free travel for citizens of the Community in alignment with Article 45 of the RTC (*linked with the Transportation Infrastructure and Services strategy in Strategy Priority 1*).
 4. **UNY 4 - Strengthen Relationships among Member States** - deepening trust and unity among Member States and advancing intra-Community relations which will involve promoting specific opportunities for bilateral and multilateral cooperation and social and economic development.

4.2.5.4 Key Considerations

1. **Heads of Government, the Secretary-General, Heads of Regional Institutions** and other leaders across the Region (faith based, private sector, labour, NGOs, opposition parties) must be **consistent advocates for building the CARICOM Identity** and Spirit of Community.
2. **Universities** across the Region as environments for learning and social interaction must also continue to play their role to unify the people of the Region.
3. **The media** (traditional and non-traditional) has played, and must continue to play, a vital role in strengthening the Community.
4. **Communications** will provide a framework for coordinated action for all CARICOM entities to contribute to creating awareness and building regional unity - Member States, Secretariat, Institutions.
5. Social Cohesion across the Community must be underpinned by **multi-language, culturally customized engagement and communications**.
6. **Projecting One Voice as a Community through coordinated foreign policy** as a symbol of unity both within the Region and in the International arena. Also as a means for deepening trust and relationships between the People of the Region and the Member States.
7. **Mobilise resources** to sustain a communications programme which itself is essential for building the unity/ 'mind set' for successful regional integration.

FIGURE 4: DESCRIPTION OF THE IDEAL CARIBBEAN PERSON²⁰

THE IDEAL CARIBBEAN PERSON

Ideal Caribbean Person, defined by CARICOM as someone who, among other things:

- ◆ is imbued with a respect for human life since it is the foundation on which all the other desired values must rest;
- ◆ is emotionally secure with a high level of self-confidence and self-esteem;
- ◆ sees ethnic, religious and other diversity as a source of strength and richness;
- ◆ is aware of the importance of living in harmony with the environment;
- ◆ has a strong appreciation of family and kinship values, community cohesion, and moral issues including responsibility for and accountability to self and community;
- ◆ has an informed respect for the cultural heritage;
- ◆ demonstrates multiple literacies independent and critical thinking, questions the beliefs and practices of past and present and brings this to bear on the innovative application of science and technology to problems solving;
- ◆ demonstrates a positive work ethic;
- ◆ values and displays the creative imagination in its various manifestations and nurtures its development in the economic and entrepreneurial spheres in all other areas of life;
- ◆ has developed the capacity to create and take advantage of opportunities to control, improve, maintain and promote physical, mental, economic, social and spiritual well-being and to contribute to the health and welfare of the community and country;
- ◆ nourishes in him/herself and in others, the fullest development of each person's potential without gender stereotyping and embraces differences and similarities between females and males as a source of mutual strength.

²⁰ “*Creative and Productive Citizens for the Twenty-First Century*”, www.caricom.org. informed by the Regional Cultural Policy; the West Indian Report; the Caribbean Charter for Health Promotion; the Special Meeting of SCME, May 1997.

4.2.6 Strengthened Governance Arrangements within CARICOM

4.2.6.1 Introduction

“... the Member States transformed the erstwhile voluntary arrangements in CARICOM into a rule-based system, thus creating and accepting a regional system under the rule of law. The rule of law brings with it legal certainty and protection of rights of states and individuals alike, but at the same time, of necessity, it creates legal accountability. Even if such accountability imposes some constraint upon the exercise of sovereign rights of states, the very acceptance of such a constraint in a treaty is in itself an act of sovereignty.”²¹

The Community recognises that good governance encompasses the rule of law, democratic governance, effective citizen participation, and efficient public services in the context of a diverse Region. The rule of law is one major aspect of a governance framework which provides a foundation for sustainable development - a principle which is illustrated by quote above.

The Community law or rules-based system which governs the functions of the Community, its Organs and Bodies, comprises the Revised Treaty and related Agreements, Policies and Protocols adopted by the Community, and binding decisions of the Organs and Bodies. There is a formal structure, established by Treaty for decision-making, and monitoring of implementation. The Revised Treaty also provides for a dispute settlement mechanism, including recourse to the Caribbean Court of Justice (CCJ). The CCJ in its original jurisdiction has the exclusive and compulsory jurisdiction to determine disputes on the interpretation or application of the Revised Treaty and thereby provides, in addition to dispute resolution, definitive guidance on the application of Community law.

This strategic priority seeks to close gaps as it relates to governance of the Community and ensure effective and transparent decision-making and decision-taking, accountability and compliance with agreements and Community Law, including respect for the rule of law.

²¹ *Trinidad Cement Limited v. The Caribbean Community* ([2009] CCJ 2 (OJ) at para 32).

There is recognition that the emerging policy responsibility would require a diverse competence which cannot be readily provided by the CARICOM Secretariat alone. In this context, it will be important to draw from the competence residing across the Community, particularly Member States, regional Institutions, regional private sector, regional labour representatives, and subject matter specialists amongst others.

Over the Plan period, the strategy will involve:

- ⦿ Reforming existing arrangements to enhance decision making, implementation, accountability, compliance and enforcement.
- ⦿ Developing arrangements for participatory governance.
- ⦿ Developing governance arrangements for Community Institutions.
- ⦿ Strengthening relationships with IDPs.
- ⦿ Developing and agreeing on the desired governance arrangements for the future.

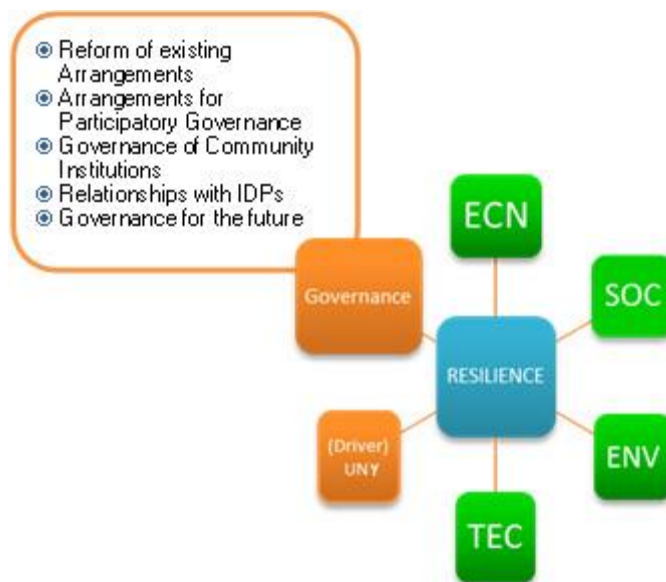

4.2.6.2 Goal - Strengthening Governance Arrangements in CARICOM (GOV)

- ⦿ To ensure effective and efficient governance arrangements that support good decision making, successful implementation of the regional agenda and accountability by all actors.²²

²² Reforming and strengthening governance is seen as vital for improving success in CARICOM. Stakeholders note that the governance arrangements should be based on and be consistent with strengthening the operation of the rule of law in the governance arrangements for the Community. All parties need to know the rules and the consequences of their conduct with a greater degree of certainty, and all actors including states actors, Organs and Institutions of the Community and persons, need to operate according to these rules and procedures laid down. Business enterprise, commercial activity, investment, trade, the entrepreneurial spirit, and economic growth will be enhanced and promoted by the certainty that is created when there are clear and predictable governing rules, clearly defined rights and obligations that are easily accessible to all, under which all parties must operate. There is a strong desire to do the things we need to, as a community, to achieve growth and prosperity. The reform process offers a unique opportunity to address these matters.

4.2.6.3 Strategies

1. **GOV 1- Reform of Organs, Bodies and Governance Arrangements to Enhance Decision-Making, Implementation and Accountability and Enforcement** - This strategy involves improving existing arrangements to desired levels of efficiency and effectiveness viz.:

(a) Enabling improved decision-making and implementation through:

- i. *Improving the operations of the Organs and Bodies of the Community*, in particular the Community Council as it relates to the strategic role of this organ and the reform of the CCS. Among the initiatives will be establishing a performance framework for the Organs to assess their results, improving the conduct of meetings, improving coordination across Councils, gaining commitment for ministerial representation at meetings, formalizing the participation/consultation with non-state actors, the use of think-tanks to support the Councils;
- ii. *Improving the decision-making process* through reviewing, refining and promoting decision-making protocols, strengthening the preparatory process, including feasibility/resource/cost-benefit analysis; improving the management of meetings by focused discussion and taking of strategic decisions.

Further to (i) and (ii) above the following arrangements are proposed:

- iii. *Introducing the Committee of Ambassadors* as the nexus between national/Member State needs and the regional agenda, a requirement for successful transposition in CARICOM.²³ Working with the Secretary-General and the CCS, the Organs of the Community, their Ministers, Senior Officials and CARICOM Units in their Member States, the Ambassadors will bring the issues to bear in the agenda setting and policy formulation and with a mandate to ensure the implementation of the regional agenda at the national level, including addressing challenges and

²³ Noted in the Discussion Paper on Governance, based on the deliberations of the TWG on Governance, 2010

'breaking log jams' that stymie implementation; as well as monitor and track the results and the benefits which accrue. In that regard, the Committee is intended to provide a range of services which will complement the work of the Organs and of the Secretariat (the best practice example of the OECS Commissioners is noted);

- iv. Formalise the current Forum of the Secretary-General and Heads of Community Institutions to facilitate coordinated implementation of the Strategic Plan. This Forum will be convened by the Secretary-General and can be expanded to include the Committee of Ambassadors, and the Private Sector and Civil Society as needed, for consultation, strategic discussion and guidance on specific issues (committee of the whole).

Further to the reform of operating procedures and governance structures, the following is proposed to strengthen decision making and implementation:

- v. *Strengthening the executive role and function of the Community Council and Secretary-General* as intended by the RTC. For the Community Council, the executive function will be strengthened as it relates to its role in monitoring the policy and decision-making process, as well as implementation of mandates, ensuring compliance to Treaty obligations and mandates among Member States and ensuring the efficiency of the Conference of Heads of Government. Similarly, the Secretary-General will need to act and take decisions regarding the approach to and optimal use of resources in pursuit of mandates. The development of the Strategic Plan for the Community provides the opportunity for a Community-wide approach to managing the regional integration process. However, a key consideration is the role of the Secretary-General, in the capacity of CEO of the Community, providing oversight to the work of the Community Institutions;

- (b) **Support Implementation in Member States** by harmonizing functions and responsibilities and building capacity of CARICOM Units in Member States (building on previous initiatives to develop a model for Regional Integration Implementation Units) as well as other 'partner' public sector ministries or institutions. These Units should be headed by the CARICOM Ambassador. Additional measures to support implementation in Member States include

creating fora for engaging Permanent Secretaries and Senior Officials, as well as private sector and civil society partners; deepening the role of the Assistant Secretaries General of the CARICOM Secretariat as a 'bridge' with Member States; improving access to CARICOM Institutions; and providing critical support services through a reformed CCS;

- (c) **Enable Compliance, Accountability and Enforcement** by fully utilising mechanisms for dispute settlement, agreeing on appropriate sanctions, and enforcement through the CCJ;²⁴ bearing in mind the Community is moving increasingly towards a rules based system.

2. GOV 2 - Develop Arrangements for Participatory Governance in the Community

In the Plan period, action will be taken to develop mechanisms for participatory governance arrangements in CARICOM. Three primary undertakings will be i) Forum for Parliamentarians; ii) Promoting discussion on CARICOM Issues at national parliamentary assemblies and iii) Fora for Civil Society and the Private Sector:

- (a) ***Forum for Parliamentarians*** - Over the planning period, consideration would be given to re-engineering the Assembly of Caribbean Community Parliamentarians (ACCP), or a similar Forum could be developed comprising government and opposition representatives from each Member State. Such a Forum will have the benefits of:
 - i. Ensuring inclusive, participatory engagement and decision-making across the Community on Community matters;
 - ii. Facilitating the inclusion of CARICOM and regional integration matters in the strategic documents of political parties in Member States;

²⁴ Stakeholders have emphasized that special attention should be given to the role of the CCJ in strengthening and optimizing the governance arrangements. In that regard, Governments need to signal greater commitment to the CCJ and improve utilization of the Court, for example to: i) resolve disputes in a speedy manner on the basis of regional and international law; ii) draw on the competence of the Court in interpreting and applying the RTC and related decisions of the Organs of the Community; and/or iii) develop the regional legal framework to achieve greater clarity and certainty regarding the rights and duties of all actors of the Community.

- iii. Demonstrating tangibly the viability of regional development to the people of the Community through inclusive, participatory dialogue and decision making;
 - iv. Engaging the people of the Community;
- (b) *Promote discussion on CARICOM Issues at national parliamentary assemblies.* This may include advocating for Member States to agree to set aside a time period each year for discussions on CARICOM Issues. It is noted that these debates can also be used to engage the people of the Community on issues;
- (c) *Fora for Private Sector, Civil Society* - Establishing a permanent arrangement for engagement/consultation with the regional representatives of private sector and civil society (NGOs, Labour, Youth, Media etc.) at the meetings of Councils. Ongoing information sharing and engagement of these stakeholder groups will also be facilitated, using technology, as well as through the CARICOM Ambassadors in Member States.

In addition, the development of national level consultative mechanisms will be facilitated, for example, to establish inter-ministerial consultative committees, business and labour advisory committees, and fora for civil society for regular consultation with stakeholders. The fora at the national level will support and facilitate a consultative mechanism at the regional level.

3. **GOV 3 - Develop Governance Arrangements for Community Institutions** - This strategy will focus on reviewing and developing the governance arrangements for the Community Institutions in order to create an enabling environment for coordinated management across the Regional Integration Architecture. The objective is to ensure that the Community Institutions are best positioned to contribute to the effective implementation of the resilience building agenda within the context of the Strategic Plan. This strategy will address:

- (a) Strengthening of accountability mechanisms and harmonization of institutional arrangements;²⁵
- (b) Development and application of a shared performance framework based on the Community Strategic Plan;
- (c) Mechanisms for greater collaboration among Institutions and with the CCS;
- (d) Use of relevant tools to support collaboration, coordination and accountability e.g. MOUs, Service agreements;
- (e) Use of ICT tools to support information sharing, and development and implementation of collaborative programmes and functional cooperation initiatives.

The development of governance arrangements will occur in the wider review of the Institutions to be conducted in the Plan period.

4. **GOV 4 - Strengthen Relationships and Build Partnerships with International Development Partners (IDPs)** to support CARICOM priorities and positions. The Community will hold regular and structured engagements with IDPs, both traditional and new Partners, guided by the priorities set out in the Strategic Plan. Such engagements would involve Member States, the CARICOM Secretariat and Community Institutions. Additionally, the Community will take steps for greater coordination and effectiveness in the use and management of IDP resources.
5. **GOV 5 - Develop and Agree on the Desired Governance Arrangements for the Future -** Over the Plan period, there should be fora for consultation and dialogue among stakeholders and Community nationals, to develop a long term view of the integration for the Region, as it relates to both economic and political integration. Part of this discussion will take account of the governance arrangements required for the desired form of integration and the steps to be taken in that regard.

²⁵ Harmonization of institutional arrangements such as operational policies and procedures, including accounting, procurement, as well as human resource management policies etc across regional institutions. The aim would be to have minimum standards that are consistent with internationally recognized best practice

4.2.6.4 Key Considerations

1. The strategies outlined above are mutually supportive and action in one area is likely to contribute to progress in all other areas. It is critical that there is an acceptance at the outset of the need for major changes in the principles and practices that underpin governance in the Community.
2. The Community will be guided by principles of **good governance** including transparency, accountability, respect for human rights, participation by all stakeholders, equity, justice, respect for the rule of law and clearly defined roles and responsibilities.
3. The Community must **speak with one voice** in the global arena as well as within the Region and harmonise relevant policies and legislation.
4. The OECS **sub-regional grouping** is further along with its integration process than the wider CARICOM grouping and, in that regard, may choose to act as one on matters of exclusive competence by the Economic Union, which must be accommodated in the initiatives outlined to strengthen the governance arrangements.
5. **Participatory governance** will require strengthening of civil society representative organisations, with formal mechanisms to engage these organisations on a regular basis, recognizing that consultation begins at the national level.
6. The **roles and responsibilities** of Community Institutions must be clear to guide their review and rationalisation and formalise their relationship with the Principal Organs, Organs and Bodies to reinforce their position as part of the Regional Integration Architecture.
7. There must be **continuing review of the Revised Treaty of Chaguaramas** to reflect new arrangements.
8. The governance arrangements proposed will inform the **performance framework** for actors within the Community.
9. The initiatives proposed will mean new ways of working, and a **change management approach** will be adopted to support the required shifts in thinking and behavior. The Change Management Strategy going forward is further discussed in Chapter 7 of this Plan.

4.2.7 Enabling Resilience: Coordinated Foreign and External Relations and Research and Development and Innovation

4.2.7.1 Introduction

Effective foreign policy coordination will be an important enabler of building resilience by favourably positioning CARICOM and the Member States in the global arena; facilitating collaboration, cooperation and strategic alliances with like-minded countries and groups; promoting and protecting the interest of CARICOM and other small states to mitigate vulnerability and leveraging resources for external sources for regional priorities.

A second, 'cross cutting' enabler for success is Research and Development (R&D) and innovation. These elements need to drive the development process going forward and in that regard, should be infused and mainstreamed into every aspect of the planning and implementation.

4.2.7.2 Goal - Enabling Building Resilience

- ⦿ A coordinated approach to international relations that facilitates CARICOM being an active player in the international environment and advances the development of the Region.
- ⦿ To engender innovative, knowledge driven development within the Community, and unleash the creative talent of the people of the Community.

4.2.7.3 Strategies

1. **FOR 1 - Deepen foreign policy coordination to support the achieving of CARICOM's strategic priorities and desired outcomes.** This strategy will involve:
 - (a) Securing recognition, acceptance and implementation of CARICOM positions, interests and initiatives;
 - (b) Developing strategic alliances in the changing international environment;

- (c) Maintaining and strengthening relations with traditional partners;
- (d) Strengthening the collaboration and cooperation with third countries and groups;
- (e) Mobilising resources externally to address CARICOM's priorities;
- (f) Optimizing sharing of foreign missions.

2. RDI 1 - Mainstreaming Research and Development and Innovation in all aspects of development of the Region. This strategy will involve initiatives to:

- (a) Consistently adopt an evidenced-based approach in managing the affairs of the Community, building a research agenda in collaboration with regional universities;
- (b) Advocate for resources (state and private sector) to finance R&D in business development;
- (c) Facilitate an enabling legislative environment for R&D and Innovation e.g. protection of intellectual property, incentives for the private sector, incentives for innovation which capitalize on indigenous knowledge and resources;
- (d) Identifying and promoting opportunities for functional cooperation in R&D and Innovation;
- (e) Advocate for national school based programmes (primary, secondary and tertiary) that drive, enable and reward R&D and Innovation.

4.3 Strategic Goals and Objectives to 2019

STRATEGIC PRIORITY	GOAL	STRATEGIC OBJECTIVES
1. Economic Resilience - Stabilisation and Sustainable Economic Growth and Development	<ul style="list-style-type: none"> ● To engender sustainable growth of the economies of Member States 	<ul style="list-style-type: none"> a. To restore confidence in CARICOM economies b. To reverse negative perceptions about economic management and governance in the Caribbean Community c. To lay the foundation for innovative resource mobilisation strategy to support the Growth Agenda d. To engender growth of the economies of Member States
2. Social Resilience - Equitable Human and Social Development	<ul style="list-style-type: none"> ● To ensure sustainable human and social development in the Region with reduced levels of poverty and equitable access by vulnerable groups and significant improvement of citizen security by facilitating a safe, just and free community 	<ul style="list-style-type: none"> a. To build the capacity of Caribbean people to create regenerative societies b. To forge a culture of innovation and entrepreneurship c. To eliminate the significant wastage occurring in the education systems d. To ensure that the diverse needs of the people of the Community are understood and met e. To ensure universal access to basic health services f. To reduce mortality and morbidity related to NCDs and HIV g. To disrupt, dismantle and defeat transnational organised crime h. To enhance human resource capabilities and strengthen regional security systems i. To improve the economic viability of the Region

STRATEGIC PRIORITY	GOAL	STRATEGIC OBJECTIVES
3. Environmental Resilience	<ul style="list-style-type: none"> ● To reduce vulnerability to disaster risk and the effects of climate change and ensure effective management of the natural resources across Member States 	<ul style="list-style-type: none"> a. To increase the use of clean and renewable energy b. To build capacity to manage adaptation and mitigation to climate change c. To enhance resilience to natural disasters d. To mainstream environmental sustainability into policy, planning and public education and public awareness of sustainable environmental management
4. Technological Resilience	<ul style="list-style-type: none"> ● To engender innovative, technology-driven economies and societies in the Region 	<ul style="list-style-type: none"> a. To use technology to build a competitive regional economy b. To create opportunities for the people of the Community to participate actively in the Digital Economy c. To increase public sector use and citizen adoption of e-government d. To increase job creation entrepreneurship and new business development in ICT e. To support the creation of 'Smart' (i.e. digitally enabled) Communities
5. Strengthening the CARICOM Identity and Spirit of Community	<ul style="list-style-type: none"> ● To refine and intensify the promotion of the 'CARICOM Identity' that binds the people of Member States together and engenders a sustained sense of belonging. 	<ul style="list-style-type: none"> a. To create internal cohesion, and ownership of, and support for, the work and the goals of the Community b. To advance the development agenda of the Community c. To build and foster a positive image of the Community d. To position CARICOM as a brand in the regional and international community

STRATEGIC PRIORITY	GOAL	STRATEGIC OBJECTIVES
5. Strengthening the CARICOM Identity and Spirit of Community (Cont'd)	<ul style="list-style-type: none"> ● To refine and intensify the promotion of the 'CARICOM Identity' that binds the people of Member States together and engenders a sustained sense of belonging 	<ul style="list-style-type: none"> e. To accelerate the integration of the people of the Community f. To establish and maintain productive engagements and partnerships with the stakeholders g. To engender commitment, pride and a sense of belonging among CARICOM citizens h. To increase awareness and appreciation of CARICOM Member States among the people of the Community i. To create viable social and economic relationships among the people of the Community
6. Strengthening Community Governance	<ul style="list-style-type: none"> ● To ensure effective and efficient governance arrangements that support good decision-making, successful implementation of the regional agenda and accountability by all actors 	<ul style="list-style-type: none"> a. To enhance the practice of effective governance in the Community b. To improve the efficiency of Community Organisations c. To improve the rate of implementation of Community decisions and the CARICOM agenda

SECTION C

- ① **How Will We Get Where We Wish To Be?**

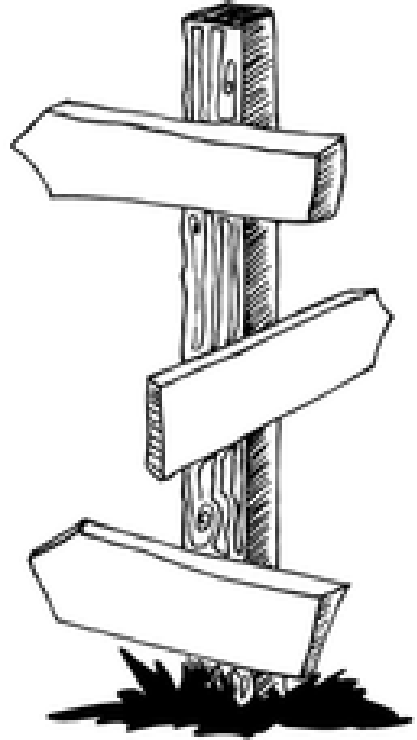

5.0 THE STRATEGIC IMPLEMENTATION FRAMEWORK

As noted above, the CARICOM Strategic Plan 2015 - 2019 provides a framework for collective and coordinated action of CARICOM's entities (that is, the Organs and Bodies, the Secretariat, the Institutions and the Member States) as well as its partners, around shared goals and objectives. Therefore, the Plan is a main driver of reform for the CARICOM architecture, in particular the reform of the governance and institutional arrangements. For example, the Strategic Plan will enable an alignment of the Strategy and Work Programmes of the Community Institutions towards agreed goals as shown in **Figure 5**.

The anticipated benefits of this new approach to strategic management of the Community includes improved monitoring and measurement of the results produced by CARICOM; coordinated efforts across institutions and, in that regard, optimization of resources (including funding). Other key benefits of this approach will be strengthened, more effective Organs; results that are 'felt on the ground' by the people of the Region, and the full realization of the objectives of the Treaty of Chaguaramas.

As a framework for action, the Plan *does not* give full details of how the strategies will be fully operationalized. This 'translation' is expected as the lead agencies develop their implementation/operational/work plans in sync with the Plan. In the process of 'operationalization', the Strategic Implementation Framework will be elaborated to include the activities and targets to be pursued by the implementing agencies towards the achievement of the goals and objectives laid out in Chapter 4. The timelines, performance indicators and indicative budget will also need to be elaborated. This adopts/adapts the model of the UN where each UN agency develops a strategic agenda and an annual programme of work in response to the MDGs.

FIGURE 5: A STRATEGIC PLAN FOR A COORDINATED COMMUNITY

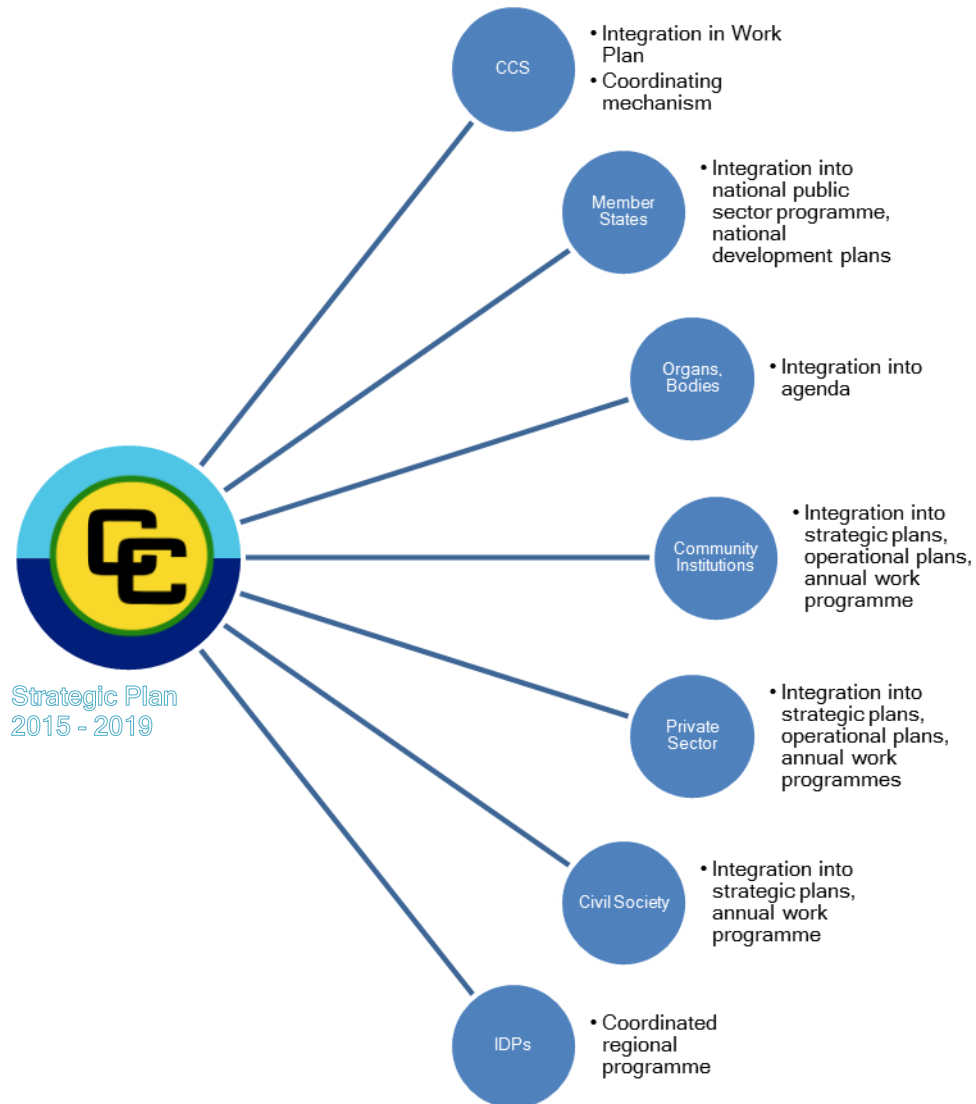

The Strategic Implementation Framework commencing on page 72, initiates this process of collaborative work planning across CARICOM entities and partners. In that regard, the framework lays out the goals, objectives, key measures to be pursued in relation to the strategic priorities. The framework also suggests the lead agencies responsible for each initiative and timelines.

Going forward, implementing agents for the Plan viz. Member States, CCS and Community Institutions, will work in collaboration to develop and agree on the key performance indicators and targets as well as the budget to implement the initiatives to be undertaken annually. This planning activity will be a formal, routine corporate activity which will produce the annual Work Programme for the Community for approval by the Community Council.

The Framework, as a key tool for ongoing strategic management, assists in selecting among initiatives/key measures that will be undertaken each year over the Plan period. Moreover, in determining the initiatives/key measures to be pursued, a number of factors are considered:

- (a) The principle of subsidiarity - the measures focus on regional initiatives that will add value to national or sub-regional initiatives, avoiding doing what can be done at the national or sub regional level;
- (b) Resource management/limited resources (human, financial) - limited resources are expected to characterise the Plan period, and, in that regard, limits the number and scope of initiatives that can be pursued annually;
- (c) Lead/support responsibilities - the organisation best able to implement having lead responsibility, with support of other organisations;
- (d) The basis for strategic management of the Community - which the framework provides, given the shift to shared objectives and a shared performance framework.

The Implementation Framework follows.

5.1 Strategic Implementation Framework for CARICOM 2015 – 2019

STRATEGIC PRIORITY		BUILDING ECONOMIC RESILIENCE - STABILISATION AND SUSTAINABLE ECONOMIC GROWTH AND DEVELOPMENT			
Goal		<ul style="list-style-type: none"> ● To engender sustainable growth of the economies of Member States 			
Strategic Objectives ⁺	Strategies	Principal Measures	Responsibility (Lead/Support)		Time Frame [*]
			Actor	Organ	
(a) To restore confidence in CARICOM economies (b) To reverse negative perceptions about economic management and governance in the Caribbean Community (c) To lay the foundation for innovative resource mobilisation strategy to support the Growth Agenda (d) To engender growth of the economies of Member States	ECN 1: Accelerate implementation and use of the CARICOM Single Market and Economy	a. Fully implement the five regimes under the CSM in Member States in accordance with agreed revised timetable ²⁶	CCS Commission on the Economy CCA Member States	COTED	ST - 2015/2016
		b. Address the constraints to intra-regional trade with a view to increasing the level of intra-CARICOM trade	CCS Transportation Commission Member States CROSQ CAHFSA	COTED	ST - 2015/2016
		c. Promotion for increased utilization of CSME arrangements	CCS Member States	COTED	ST - 2015
		d. Facilitate fuller participation by the private sector especially for production integration	Commission on the Economy CCS Member States	COTED	ST - 2015/2016

⁺ Adapted from the Preliminary Report of the Commission on the Economy, February 2014

^{*} **ST**: 'Short Term' refers to years 1 and 2 of the Plan i.e. 2015 - 2016; **MT**: 'Medium Term' refers to years 3 and 4 of the Plan, i.e. 2017 - 2018; **LT**: 'Long Term' refers to year 5 of the Plan, i.e. 2019

²⁶ Based on Recommendations of the Prime Ministerial Sub-Committee (PMSC) on the CSME, March 2014

STRATEGIC PRIORITY	BUILDING ECONOMIC RESILIENCE - STABILISATION AND SUSTAINABLE ECONOMIC GROWTH AND DEVELOPMENT				
Goal	● To engender sustainable growth of the economies of Member States				
Strategic Objectives ⁺	Strategies	Principal Measures	Responsibility (Lead/Support)		Time Frame [*]
			Actor	Organ	
(a) To restore confidence in CARICOM economies (b) To reverse negative perceptions about economic management and governance in the Caribbean Community	ECN 2: Integrate into the Global Economy	a. Attract foreign direct investment through promotion of joint ventures and public private partnerships	CCS CCA Member States Commission on the Economy Caribbean Export	COTED COFAP	ST - 2015/2016
(c) To lay the foundation for innovative resource mobilisation strategy to support the Growth Agenda (d) To engender growth of the economies of Member States		b. Address the conditions/factors for creating an enabling environment to facilitate the private sector, taking advantage of opportunities under existing and future trade agreements			

+ Adapted from the Preliminary Report of the Commission on the Economy, February 2014

* **ST:** 'Short Term' refers to years 1 and 2 of the Plan i.e. 2015 - 2016; **MT:** 'Medium Term' refers to years 3 and 4 of the Plan, i.e. 2017 - 2018; **LT:** 'Long Term' refers to year 5 of the Plan, i.e. 2019

STRATEGIC PRIORITY					
BUILDING ECONOMIC RESILIENCE - STABILISATION AND SUSTAINABLE ECONOMIC GROWTH AND DEVELOPMENT					
Goal					
● To engender sustainable growth of the economies of Member States					
Strategic Objectives ⁺	Strategies	Principal Measures	Responsibility (Lead/Support)		Time Frame [*]
			Actor	Organ	
(a) To restore confidence in CARICOM economies	ECN 3: Introduce Measures for Macroeconomic Stabilisation	a. Implement the programme of action outlined by the Commission on the Economy - short and medium term initiatives viz. fiscal sustainability ²⁷	CCS Member States CDB Committee of Central Bank Governors IFIs IDPs Various other Organisations ²⁸	COFAP COFCOR COHSOD COTED	ST - LT
(b) To reverse negative perceptions about economic management and governance in the Caribbean Community					
(c) To lay the foundation for innovative resource mobilisation strategy to support the Growth Agenda					
(d) To engender growth of the economies of Member States	ECN 4: Build Competitiveness and Unleash Key Economic Drivers to Transition to Growth	a. Advance formulation of regional policies to support production integration in target sectors ²⁹ (enable CSME)	Commission on the Economy CCS CDF CDB CARDI CTU Transportation Commission Caribbean Export CRFM	COTED	ST - LT

⁺ Adapted from the Preliminary Report of the Commission on the Economy, February 2014

^{*} **ST:** 'Short Term' refers to years 1 and 2 of the Plan i.e. 2015 - 2016; **MT:** 'Medium Term' refers to years 3 and 4 of the Plan, i.e. 2017 - 2018; **LT:** 'Long Term' refers to year 5 of the Plan, i.e. 2019

²⁷ Suggested actions include buy-back of existing high cost bonds, voluntary debt/bond at par exchange programmes for existing government debt held by public institutions; a Programme of International Advocacy for Debt Relief (Preliminary Report of the CARICOM Commission on the Economy, February 2014)

²⁸ Several Community Institutions, Ministries and Public Agencies in Member States, private sector and international partners will collaborate on implementation

²⁹ Target Sectors - agriculture, tourism, manufacturing, services (e.g. cultural, health, medical and wellness)

STRATEGIC PRIORITY	BUILDING ECONOMIC RESILIENCE - STABILISATION AND SUSTAINABLE ECONOMIC GROWTH AND DEVELOPMENT				
Goal	● To engender sustainable growth of the economies of Member States				
Strategic Objectives ⁺	Strategies	Principal Measures	Responsibility (Lead/Support)		Time Frame [*]
			Actor	Organ	
(a) To restore confidence in CARICOM economies (b) To reverse negative perceptions about economic management and governance in the Caribbean Community (c) To lay the foundation for innovative resource mobilisation strategy to support the Growth Agenda (d) To engender growth of the economies of Member States	ECN 4 (Cont'd): Build Competitiveness and Unleash Key Economic Drivers to Transition to Growth	b. Implement the programme of action outlined by the Commission on the Economy - short and medium term initiatives viz. private sector stimulation and the business regulatory environment. ³⁰	CCS Member States Various Organisations	COTED COFAP	ST - LT
		c. Institute arrangements for ongoing engagement with private sector	CCS Member States	COTED	ST - 2015

⁺ Adapted from the Preliminary Report of the Commission on the Economy, February 2014

^{*} **ST:** 'Short Term' refers to years 1 and 2 of the Plan i.e. 2015 - 2016; **MT:** 'Medium Term' refers to years 3 and 4 of the Plan, i.e. 2017 - 2018; **LT:** 'Long Term' refers to year 5 of the Plan, i.e. 2019

³⁰ Immediate actions include developing a single jurisdiction for registration and incorporation; encouraging consolidation of government agencies with similar functions serving the business sector

STRATEGIC PRIORITY		BUILDING ECONOMIC RESILIENCE - STABILISATION AND SUSTAINABLE ECONOMIC GROWTH AND DEVELOPMENT			
Goal		<ul style="list-style-type: none"> ● To engender sustainable growth of the economies of Member States 			
Strategic Objectives ⁺	Strategies	Principal Measures	Responsibility (Lead/Support)		Time Frame [*]
			Actor	Organ	
(a) To restore confidence in CARICOM economies	ECN 4 (Cont'd): Build Competitiveness and Unleash Key Economic Drivers to Transition to Growth	d. Advance Development of Strategic Plan for the Services sector	CCS Coalition of Service Providers	COTED	ST - 2015
(b) To reverse negative perceptions about economic management and governance in the Caribbean Community		e. Implement the Programme of Action outlined by the Commission on the Economy - short and medium term Initiatives viz. Transitioning to Sustainable Growth	Member States CCS Various Organisations	COFAP	ST - LT
(c) To lay the foundation for innovative resource mobilisation strategy to support the Growth Agenda		f. Advance Implementation of the Common Agriculture Policy, Food and Nutrition Security Policy, such as: <ul style="list-style-type: none"> - Establishing a system of regional indicators for Agriculture - Advancing initiatives for an enabling environment in Member States for attracting investment in small and large scale production of selected commodities, and encouraging entrepreneurship among youth, women and small farmers - A fully integrated and harmonized Regional Agricultural Health and Food Safety System - Risk mitigation for climate change 	CCS CARDI CCCCC CRFM CAHFSA UWI	COTED	ST - MT
(d) To engender growth of the economies of Member States					

⁺ Adapted from the Preliminary Report of the Commission on the Economy, February 2014

^{*} **ST**: 'Short Term' refers to years 1 and 2 of the Plan i.e. 2015 - 2016; **MT**: 'Medium Term' refers to years 3 and 4 of the Plan, i.e. 2017 - 2018; **LT**: 'Long Term' refers to year 5 of the Plan, i.e. 2019

STRATEGIC PRIORITY		BUILDING ECONOMIC RESILIENCE - STABILISATION AND SUSTAINABLE ECONOMIC GROWTH AND DEVELOPMENT			
Goal		● To engender sustainable growth of the economies of Member States			
Strategic Objectives ⁺	Strategies	Principal Measures	Responsibility (Lead/Support)		Time Frame [*]
			Actor	Organ	
(a) To restore confidence in CARICOM economies (b) To reverse negative perceptions about economic management and governance in the Caribbean Community (c) To lay the foundation for innovative resource mobilisation strategy to support the Growth Agenda (d) To engender growth of the economies of Member States	ECN 4 (Cont'd): Build Competitiveness and Unleash Key Economic Drivers to Transition to Growth	g. Implement the programme of action outlined by the Regional Transportation Commission - short and medium term initiatives viz. - The framework for effective delivery of air and maritime transportation - Cost and sustainability of transportation - Ease of travel in the Region	CCS Member States Various Organisations Regional Airlines Caribbean Shipping Association	COTED	ST - LT

⁺ Adapted from the Preliminary Report of the Commission on the Economy, February 2014

^{*} **ST**: 'Short Term' refers to years 1 and 2 of the Plan i.e. 2015 - 2016; **MT**: 'Medium Term' refers to years 3 and 4 of the Plan, i.e. 2017 - 2018; **LT**: 'Long Term' refers to year 5 of the Plan, i.e. 2019

STRATEGIC PRIORITY	BUILDING ECONOMIC RESILIENCE - STABILISATION AND SUSTAINABLE ECONOMIC GROWTH AND DEVELOPMENT				
Goal	<ul style="list-style-type: none"> ● To engender sustainable growth of the economies of Member States 				
Strategic Objectives ⁺	Strategies	Principal Measures	Responsibility (Lead/Support)		Time Frame [*]
			Actor	Organ	
(a) To restore confidence in CARICOM economies	ECN 4 (Cont'd): Build Competitiveness and Unleash Key Economic Drivers to Transition to Growth	h. Advance implementation of priority actions of the CARICOM Energy Policy	CCS Member States CCCC CDB	COTED	ST - MT
(b) To reverse negative perceptions about economic management and governance in the Caribbean Community		i. Advance ICT development in accordance with Strategic Priority 4	CCS CTU CKLNA UWI	COTED	ST - LT
(c) To lay the foundation for innovative resource mobilisation strategy to support the Growth Agenda		j. Implement the programme of action outlined by the Commission on the Economy - short and medium term initiatives viz. Resource mobilisation	CCS Member States Various Organisations CDB CDF	COFAP COTED	
(d) To engender growth of the economies of Member States					

⁺ Adapted from the Preliminary Report of the Commission on the Economy, February 2014

^{*} **ST:** 'Short Term' refers to years 1 and 2 of the Plan i.e. 2015 - 2016; **MT:** 'Medium Term' refers to years 3 and 4 of the Plan, i.e. 2017 - 2018; **LT:** 'Long Term' refers to year 5 of the Plan, i.e. 2019

STRATEGIC PRIORITY	BUILDING SOCIAL RESILIENCE - EQUITABLE HUMAN AND SOCIAL DEVELOPMENT				
Goal	<ul style="list-style-type: none"> To ensure sustainable human and social development in the Region with reduced levels of poverty and equitable access by vulnerable groups and significant improvement of citizen security by facilitating a safe, just and free community 				
Strategic Objectives	Strategies	Principal Measures	Responsibility (Lead/Support)		Time Frame*
			Actor	Organ	
(a) To build the capacity of Caribbean people to create regenerative societies (b) To forge a culture of innovation and entrepreneurship (c) To eliminate the significant wastage occurring in the education systems	SOC 1: Advance Human Capital Development: Key Skills, Education Reform and Youth Development	a. Develop a Regional Education and Human Resource Development 2030 Strategy to create a workforce for the 21 st Century. ³¹	Commission on HRD ³² CCS CXC UWI IDPs CANTA ACTI CDB	COSHOD	ST - 2016
		b. Identify and seek to address critical skill gaps required for successful implementation of regional integration initiatives and advancement of the CARICOM agenda ³³ and develop target programmes through national and regional tertiary institutions	Commission on HRD CCS CXC UWI IDPs CANTO ACTI CDB	COSHOD COTED	ST - 2015/2016
		c. Support national implementation of actions in the CYDAP 2012 - 2017 viz. Goals 1, 2, 3. ³⁴	CCS CYAs CCA Member States	COSHOD	ST - MT - 2017

* **ST:** 'Short Term' refers to years 1 and 2 of the Plan i.e. 2015 - 2016; **MT:** 'Medium Term' refers to years 3 and 4 of the Plan, i.e. 2017 - 2018; **LT:** 'Long Term' refers to year 5 of the Plan, i.e. 2019

³¹ Decision of the Heads of Government at the 25th Inter-Sessional, March 2014

³² The Commission is to be established in 2014

³³ In developing their Programme of Action, the Commission on the Economy, Regional Transport Commission and other working groups will identify critical skills needed

³⁴ CYDAP 2012 - 2017: Goal 1: Education and Economic Empowerment; Goal 2: Protection, Safety and Security; Goal 3: Health and Well Being.

STRATEGIC PRIORITY	BUILDING SOCIAL RESILIENCE - EQUITABLE HUMAN AND SOCIAL DEVELOPMENT				
Goal	<ul style="list-style-type: none"> ● To ensure sustainable human and social development in the Region with reduced levels of poverty and equitable access by vulnerable groups and significant improvement of citizen security by facilitating a safe, just and free community 				
Strategic Objectives	Strategies	Principal Measures	Responsibility (Lead/Support)		Time Frame*
(d) To ensure that the diverse needs of the people of the Community are understood and met	SOC 2: Mainstream inclusiveness in the Public Policy: Gender, Persons with Disabilities, Age	a. Develop and institute a regional support programme to build capacity in public sector organisations to undertake analysis, data collection and budgeting to support mainstreaming for gender, disability and the aged	CCS UWI CCA Member States	COSHOD	ST - MT
(e) To ensure universal access to basic health services (f) To reduce mortality and morbidity related to NCDs and HIV	SOC 3: Advance Initiatives for Health and Wellness	a. Explore options for developing a regional insurance system for a basic package of services ³⁵ based on a costing of services.	CCS CARPHA	COSHOD COFAP	MT - LT
		b. Advance implementation of HIV initiatives in accordance with programme of action under the Global Fund Programme	PANCAP CCS IDPs	COSHOD	ST - LT
		c. Further implementation of the Strategic Plan of Action for the Prevention and Control of NCDs	CCS CARPHA CCA Member States	COSHOD	ST - LT
		d. Create an enabling environment and facilitate inter-sectoral actions for improved health and wellness across the Community	CCS CARPHA Member States	COSHOD	ST 2015/2016

* **ST:** 'Short Term' refers to years 1 and 2 of the Plan i.e. 2015 - 2016; **MT:** 'Medium Term' refers to years 3 and 4 of the Plan, i.e. 2017 - 2018; **LT:** 'Long Term' refers to year 5 of the Plan, i.e. 2019

³⁵ Basic package may include - primary care services, prevention, treatment and care for NCDs, HIV, mental health.

STRATEGIC PRIORITY		BUILDING SOCIAL RESILIENCE - EQUITABLE HUMAN AND SOCIAL DEVELOPMENT			
Goal		<ul style="list-style-type: none"> To ensure sustainable human and social development in the Region with reduced levels of poverty and equitable access by vulnerable groups and significant improvement of citizen security by facilitating a safe, just and free Community 			
Strategic Objectives	Strategies	Principal Measures	Responsibility (Lead/Support)		Time Frame *
			Actor	Organ	
(g) To disrupt, dismantle and defeat transnational organised crime (h) To enhance human resource capabilities and strengthen regional security systems (i) To improve the economic viability of the Region	SOC 4: Enhance Citizen Security and Justice	a. Develop mechanism to identify and facilitate the tracing of criminal assets and strengthen the Region's capacity in investigation methods and techniques	IMPACS Member States CCS	CONSLE	ST - MT
		b. Develop training programmes for law enforcement and security officials and expansion of regional Centres of Excellence	IMPACS Member States	CONSLE	
		c. Strengthen regional human resource and infrastructural capacity to deal with cyber security threats	IMPACS Member States CCS CTU	CONSLE COTED	
		d. Expand the existing Advance Passenger Information System (APIS) and establish the Advance Cargo Information System (ACIS)	IMPACS Members States CCS	CONSLE	
		e. Increase Trans-border Intelligence and Information Sharing	IMPACS Members States	CONSLE	

* **ST:** 'Short Term' refers to years 1 and 2 of the Plan i.e. 2015 - 2016; **MT:** 'Medium Term' refers to years 3 and 4 of the Plan, i.e. 2017 - 2018; **LT:** 'Long Term' refers to year 5 of the Plan, i.e. 2019

STRATEGIC PRIORITY	BUILDING SOCIAL RESILIENCE - EQUITABLE HUMAN AND SOCIAL DEVELOPMENT				
Goal	<ul style="list-style-type: none"> To ensure sustainable human and social development in the Region with reduced levels of poverty and equitable access by vulnerable groups and significant improvement of citizen security by facilitating a safe, just and free Community 				
Strategic Objectives	Strategies	Principal Measures	Responsibility (Lead/Support)		Time Frame *
(g) To disrupt, dismantle and defeat transnational organised crime	SOC 4 (Cont'd): Enhance Citizen Security and Justice	f. Pursue Functional Cooperative Security engagements to tackle and manage shared risk and threat	IMPACS Member States	CONSLE	ST - MT
(h) To enhance human resource capabilities and strengthen regional security systems		g. Deepen crime prevention initiatives and programmes	CCS	CONSLE COTED	
(i) To improve the economic viability of the Region		h. Reform of Justice Systems across the Region	CCS UWI CCJ	LAC	

* **ST:** 'Short Term' refers to years 1 and 2 of the Plan i.e. 2015 - 2016; **MT:** 'Medium Term' refers to years 3 and 4 of the Plan, i.e. 2017 - 2018; **LT:** 'Long Term' refers to year 5 of the Plan, i.e. 2019

STRATEGIC PRIORITY	BUILDING ENVIRONMENTAL RESILIENCE				
Goal	<ul style="list-style-type: none"> To reduce vulnerability to disaster risk and the effects of climate change and ensure effective management of the natural resources across Member States 				
Strategic Objectives	Strategies	Principal Measures	Responsibility (Lead/Support)		Time Frame *
			Actor	Organ	
(a) To increase the use of clean and renewable energy (b) To build capacity to manage adaptation and mitigation to climate change (c) To enhance resilience to natural disasters (d) To mainstream environmental sustainability into policy, planning and public education and public awareness of sustainable environmental management	ENV 1: Advance Climate Adaptation and Mitigation	a. Ensure the periodic updating of the Regional Framework for Achieving Development Resilient to Climate Change and the Implementation Plan 2011-2021, to guarantee continued currency with national and regional development imperatives b. Pursue the full operationalization of the Implementation Plan and secure complete integration of its elements into national and regional development agendas c. Prepare Member States to be in a state of climate finance readiness d. Support the development of a compendium of projects of Member States for action by the CCCCC and its partners, to leverage the financing to support implementation of national resilience-building initiatives e. Promote actions to derive benefits from the international response to climate change	CCCCC CCS CARDI ³⁶ CCA ³⁷ Member States CIMH CDB UWI	COTED (Env) COFCOR	ST - LT

* **ST:** 'Short Term' refers to years 1 and 2 of the Plan i.e. 2015 - 2016; **MT:** 'Medium Term' refers to years 3 and 4 of the Plan, i.e. 2017 - 2018; **LT:** 'Long Term' refers to year 5 of the Plan, i.e. 2019

³⁶ Climate Change and agriculture development, water and soil management

³⁷ Including support for building institutional capacity in the Public Sector for Climate Adaptation

STRATEGIC PRIORITY	BUILDING ENVIRONMENTAL RESILIENCE				
Goal	<ul style="list-style-type: none"> To reduce vulnerability to disaster risk and the effects of climate change and ensure effective management of the natural resources across Member States 				
Strategic Objectives	Strategies	Principal Measures	Responsibility (Lead/Support)		Time Frame *
			Actor	Organ	
(a) To increase the use of clean and renewable energy (b) To build capacity to manage adaptation and mitigation to climate change (c) To enhance resilience to natural disasters (d) To mainstream environmental sustainability into policy, planning and public education and public awareness of sustainable environmental management	ENV 2: Advance Disaster Mitigation and Management	a. Integrate CDM into national policies, strategies and legislation	CDEMA CCS CCA Member States	COTED (Env)	ST - MT
		b. Strengthen national and regional institutional capacities for effective support of CDM implementation, monitoring and evaluation	CDEMA CCS CCA Member States	COTED (Env)	ST - MT
		c. Enhance preparedness and capacity for effective and efficient coordination of response and recovery at the national and regional levels	CDEMA CCS CCA Member States CCRIF	COTED (Env)	ST - 2016
		d. Build an infrastructure for fact-based policy and decision making	CDEMA CCS CCA Member States	COTED (Env)	ST
		e. Improve integrated risk management at the sectoral level for key priority sectors	CDEMA CCS CCA CARDI CIMH Member States Various other Organisations	COTED (Env)	ST

* **ST:** 'Short Term' refers to years 1 and 2 of the Plan i.e. 2015 - 2016; **MT:** 'Medium Term' refers to years 3 and 4 of the Plan, i.e. 2017 - 2018; **LT:** 'Long Term' refers to year 5 of the Plan, i.e. 2019

STRATEGIC PRIORITY	BUILDING ENVIRONMENTAL RESILIENCE				
Goal	<input checked="" type="radio"/> To reduce vulnerability to disaster risk and the effects of climate change and ensure effective management of the natural resources across Member States				
Strategic Objectives	Strategies	Principal Measures	Responsibility (Lead/Support)		Time Frame *
			Actor	Organ	
(a) To increase the use of clean and renewable energy (b) To build capacity to manage adaptation and mitigation to climate change (c) To enhance resilience to natural disasters (d) ection	ENV 3: Enhance Management of the Environment and Natural Resources	a. Develop and institute a Common Environmental and Natural Resources Management Framework	CCS Member States	COTED (Env)	MT - 2017

* **ST:** 'Short Term' refers to years 1 and 2 of the Plan i.e. 2015 - 2016; **MT:** 'Medium Term' refers to years 3 and 4 of the Plan, i.e. 2017 - 2018; **LT:** 'Long Term' refers to year 5 of the Plan, i.e. 2019

STRATEGIC PRIORITY	BUILDING TECHNOLOGICAL RESILIENCE				
Goal	<input checked="" type="radio"/> To engender innovative, technology-driven economies and societies in the Region				
Strategic Objectives	Strategies	Principal Measures	Responsibility (Lead/Support)		Time Frame *
			Actor	Organ	
(a) To use technology to build a competitive regional economy (b) To create opportunities for the people of the Community to participate actively in the Digital economy (c) To increase public sector use and citizen adoption of e-government (d) To increase job creation entrepreneurship and new business development in ICT	TEC 1: Develop a Single CARICOM ICT Space	a. Development of the Road Map for the Single ICT Space	ICT Cluster ³⁸ CCS	COTED	ST - 2015
		b. Elaborate the CARICOM Digital Agenda 2025	ICT Cluster CCS	COTED	ST - 2015/2016
		c. Continue implementation of key projects which support the Single ICT Space viz. - Advance the use of C@ribnet as a research and education core - Broadband development - Legal and regulatory environment	ICT Cluster CCS	COTED	ST - MT
		d. Implement Road Map for the Single ICT Space	ICT Cluster CCS	COTED	MT - LT
	(e) To support the creation of 'Smart' (i.e. digitally enabled) communities	TEC 2: Bring Technology to the People and Transform them to Digital Citizens and Digital Entrepreneurs	a. Harness Internet-based technology to make it easier for citizens and business to interact: - E-Government, M- Government - Open Data - Sector specific applications	CCS ICT Cluster Member States	COTED

* **ST:** 'Short Term' refers to years 1 and 2 of the Plan i.e. 2015 - 2016; **MT:** 'Medium Term' refers to years 3 and 4 of the Plan, i.e. 2017 - 2018; **LT:** 'Long Term' refers to year 5 of the Plan, i.e. 2019

³⁸ The Caribbean Broadcasting Union (CBU); the Caribbean Telecommunications Union (CTU); the Caribbean Knowledge and Learning Network Agency (CKLNA); the Caribbean Centre for Development and Administration (CARICAD) and the CARICOM Secretariat; Senior ICT Officials; Lead Agencies; and the Commission on the Economy

STRATEGIC PRIORITY	BUILDING TECHNOLOGICAL RESILIENCE				
Goal	<input checked="" type="radio"/> To engender innovative, technology-driven economies and societies in the Region				
Strategic Objectives	Strategies	Principal Measures	Responsibility (Lead/Support)		Time Frame *
			Actor	Organ	
(a) To use technology to build a competitive regional economy	TEC 3: Strengthen Cyber Security	a. Advance implementation of the Crime and Security Strategy viz. Cyber Security	IMPACS CTU CCS Member States	COTED CONSLE	MT - 2018
(b) To create opportunities for the people of the Community to participate actively in the Digital economy	TEC 4: Mobilise Resources and Commitment of Member States to invest in ICT	b. Mobilise resources for ICT development: <ul style="list-style-type: none"> - Commitments of governments - International Development Partners - Public-private-people partnership <i>(in alignment with resource mobilisation initiatives determined by the Commission on the Economy)</i>	Commission on the Economy CCS CCA	COTED COFAP	ST -
(c) To increase public sector use and citizen adoption of e-government					
(d) To increase job creation entrepreneurship and new business development in ICT					
(e) To support the creation of 'Smart' (i.e. digitally enabled) communities					

* **ST:** 'Short Term' refers to years 1 and 2 of the Plan i.e. 2015 - 2016; **MT:** 'Medium Term' refers to years 3 and 4 of the Plan, i.e. 2017 - 2018; **LT:** 'Long Term' refers to year 5 of the Plan, i.e. 2019

STRATEGIC PRIORITY	STRENGTHENING THE CARICOM IDENTITY AND SPIRIT OF COMMUNITY					
Goal	To refine and intensify the promotion of the 'CARICOM Identity' that binds the people of Member States together and engenders a sustained sense of belonging.					
Strategic Objectives	Strategies	Principal Measures	Responsibility (Lead/Support)		Time Frame *	
			Actor	Organ		
(a) To create internal cohesion, and ownership of, and support for the work and the goals of the Community	UNY 1: Enhance Public Education, Public Information, Public Relations and Advocacy	a. Establish a working group/framework for the coordination of enhanced communication among all the CARICOM Entities	CCS CCA Community Institutions	Community Council	ST - 2015	
(b) To advance the development agenda of the Community		b. Establish Communications network ³⁹ across CCS, Member States and Institutions, and partners in media	CCS CCA Member States CYA Media	Community Council	ST - 2015	
(c) To build and foster a positive image of the Community		c. Build capacity within CCS: - Acquire Communications expertise - Upgrade Communications Infrastructure	CCS	Community Council	ST 2015/2016	
(d) To position CARICOM as a brand in the regional and international community		d. Implement Communications Strategy in accordance with agreed schedule ⁴⁰	CCS Member States Media Community Institutions	Community Council	ST 2015 (for start-up)	
(e) To accelerate the integration of the People of the Community		e. Institute the use of the 'double Cs' as the CARICOM brand for all Community Organisations (co-branding with Institutions)	CCS Community Institutions	Community Council	ST 2015	
(f) To establish and maintain productive engagements and partnerships with the stakeholders						
(g) To engender commitment, pride and a sense of belonging among CARICOM citizens						
(h) To increase awareness and appreciation of CARICOM Members States among the people of the Community						
(i) To create viable social and economic relationships among the people of the Community						

* **ST:** 'Short Term' refers to years 1 and 2 of the Plan i.e. 2015 - 2016; **MT:** 'Medium Term' refers to years 3 and 4 of the Plan, i.e. 2017 - 2018; **LT:** 'Long Term' refers to year 5 of the Plan, i.e. 2019

³⁹ This network refers to support Units in Member States such as Government Information Service Units and media houses and personnel. CCS has already begun engagement of these Units and Change Drivers would be another point of contact

⁴⁰ Implementing Organisations will need to agree on the schedule and ensure timely implementation of the specific actions in their remit

STRATEGIC PRIORITY	STRENGTHENING THE CARICOM IDENTITY AND SPIRIT OF COMMUNITY					
Goal	To refine and intensify the promotion of the 'CARICOM Identity' that binds the people of Member States together and engenders a sustained sense of belonging.					
Strategic Objectives	Strategies	Principal Measures	Responsibility (Lead/Support)		Time Frame*	
			Actor	Organ		
(a) To create internal cohesion, and ownership of, and support for the work and the goals of the Community	UNY 2: Refine and Promote the CARICOM Identity and Civilization	a. Design CARICOM Week as a celebration of the Region's Identity: <ul style="list-style-type: none"> Advocate for CARICOM Day in all Member States Develop a celebration of the Region's icons/heroes during CARICOM Week (July) e.g. CARICOM clubs in schools, talk shows, regional competitions, link ups, talk shows Promote the CARICOM Song 	SG, Member States	Community Council	MT 2017	
(b) To advance the development agenda of the Community			CCS Member States		ST 2015/2016	
(c) To build and foster a positive image of the Community			CCS Member States Community Institutions CYA		ST	
(d) To position CARICOM as a brand in the regional and international community		b. Ensure the inclusion of CARICOM Studies in mandatory aspects of the primary and secondary school curriculum e.g. in Social Studies, Geography, Caribbean history	c. Facilitate dialogue at all levels of the Community to refine and promote the CARICOM Identity and Civilization.	CCS Member States Community Institutions CYA	COSHOD	MT 2017/2018
(e) To accelerate the integration of the People of the Community				CXC CCS Member States		
(f) To establish and maintain productive engagements and partnerships with the stakeholders				CCA Member States CYA CCS		
(g) To engender commitment, pride and a sense of belonging among CARICOM citizens						
(h) To increase awareness and appreciation of CARICOM Members States among the people of the Community;						
(i) To create viable social and economic relationships among the people of the Community.						

* **ST:** 'Short Term' refers to years 1 and 2 of the Plan i.e. 2015 - 2016; **MT:** 'Medium Term' refers to years 3 and 4 of the Plan, i.e. 2017 - 2018; **LT:** 'Long Term' refers to year 5 of the Plan, i.e. 2019

STRATEGIC PRIORITY	STRENGTHENING THE CARICOM IDENTITY AND SPIRIT OF COMMUNITY					
Goal	To refine and intensify the promotion of the 'CARICOM Identity' that binds the people of Member States together and engenders a sustained sense of belonging.					
Strategic Objectives	Strategies	Principal Measures	Responsibility (Lead/Support)		Time Frame *	
			Actor	Organ		
(a) To create internal cohesion, and ownership of, and support for the work and the goals of the Community (b) To advance the development agenda of the Community (c) To build and foster a positive image of the Community (d) To position CARICOM as a brand in the regional and international community (e) To accelerate the integration of the People of the Community (f) To establish and maintain productive engagements and partnerships with the stakeholders (g) To engender commitment, pride and a sense of belonging among CARICOM citizens (h) To increase awareness and appreciation of CARICOM Member States among the people of the Community; (i) To create viable social and economic relationships among the people of the Community.	UNY 3: Facilitate opportunities for the people of the Region to build social and economic relationships	a. Implement CYDAP viz. Goal 4 Culture, Identity And Citizenship: Enhance the Development and Appreciation of Caribbean Culture and Identity and Commitment to Regional Integration	CCS Member States	COSHOD	ST - MT	
		b. Advocate for intra-regional tourism initiatives by Member States	CTO Member States	COTED	ST-2015	
		c. Pursue initiatives to ensure Hassle Free Travel in accordance with the programme of action developed by the Regional Transport Commission	Regional Transport Commission CCS	COTED	ST - LT <i>(Implementation schedule to be developed by Commission)</i>	
		UNY 4: Strengthen Relationships among Member States	a. Identify and promote opportunities for bilateral cooperation/functional cooperation between Member States	CCA Member States CCS	COFCOR	ST - LT

* **ST:** 'Short Term' refers to years 1 and 2 of the Plan i.e. 2015 - 2016; **MT:** 'Medium Term' refers to years 3 and 4 of the Plan, i.e. 2017 - 2018; **LT:** 'Long Term' refers to year 5 of the Plan, i.e. 2019

STRATEGIC PRIORITY	STRENGTHENING COMMUNITY GOVERNANCE				
Goal	<input checked="" type="radio"/> To ensure effective and efficient governance arrangements that support good decision-making, successful implementation of the regional agenda and accountability by all actors.				
Strategic Objectives	Strategies	Principal Measures	Responsibility (Lead/Support)		Time Frame *
			Actor	Organ	
(a) To enhance the practice of effective governance in the Community (b) To improve the efficiency of Community Organisations (c) To improve the rate of implementation of Community decisions and the CARICOM agenda	GOV 1: Reform of Organs, Bodies and Governance Arrangements to enhance Decision-Making, Implementation and Accountability and Enforcement	a. Improve the efficiency of all Organs and Bodies viz. <ul style="list-style-type: none"> - Undertake a business process review of the decision-making process and meetings management process and implement efficiency solutions - Institute a permanent schedule of regular meetings of Organs and bodies - Introduce a performance framework for Organs and standardize reporting at meetings - Implement the Committee of Ambassadors 	CCS	HGC COFCOR Community Council CONSLE COTED COFAP COSHOD LAC	ST - 2015
		b. Improve decision-making processes through reviewing, refining and promoting decision-making protocols and strengthen the preparatory process			
		c. Introduce the Committee of Ambassadors as the nexus between national/Member States needs and the regional agenda	CCS	HGC	ST
		d. Formalise the current forum of Secretary-General and Heads of Community Institutions. Forum can be expanded to include Committee of Ambassadors and Private Sector and Civil Society as needed.	CCS CCA Heads of Community Institutions	Community Council	ST - 2016

* **ST:** 'Short Term' refers to years 1 and 2 of the Plan i.e. 2015 - 2016; **MT:** 'Medium Term' refers to years 3 and 4 of the Plan, i.e. 2017 - 2018; **LT:** 'Long Term' refers to year 5 of the Plan, i.e. 2019

STRATEGIC PRIORITY		STRENGTHENING COMMUNITY GOVERNANCE			
Goal	<ul style="list-style-type: none"> To ensure effective and efficient governance arrangements that support good decision making, successful implementation of the regional agenda and accountability by all actors. 				
Strategic Objectives	Strategies	Principal Measures	Responsibility (Lead/Support)		Time Frame *
			Actor	Organ	
(a) To enhance the practice of effective governance in the Community (b) To improve the efficiency of Community Organisations (c) To improve the rate of implementation of Community decisions and the CARICOM agenda	GOV 1 (Cont'd): Reform of Organs, Bodies and Governance Arrangements to enhance Decision-Making, Implementation and Accountability and Enforcement	e. Promote accountability and enforcement measures through an enhanced executive role of the CC and Secretary-General	CCS	Community Council	ST - 2016
		f. Support Implementation in Member States by harmonizing functions and responsibilities and building capacity of CARICOM Units in Member States	CCA CCS	Community Council	ST
		g. Enable Compliance, Accountability and Enforcement within the Community Architecture	Members States CCS - SG	HGC Community Council	ST - MT
	GOV 2: Develop Arrangements for Participatory Governance	a. Develop an appropriate model for a forum for Parliamentarians	CCS	HGC	LT
		b. Promote discussion on CARICOM Issues at national parliamentary assemblies	Members States CCA	HGC	ST
		c. Develop and implement an appropriate model for participation of the private sector and civil society groups at meetings of the Organs of the Community	CCS CCA Civil Society Groups	All Organs	ST - 2015
		d. Develop and formalise National level consultative mechanisms	CCA CCS	Community Council	ST - 2015/2016

* **ST:** 'Short Term' refers to years 1 and 2 of the Plan i.e. 2015 - 2016; **MT:** 'Medium Term' refers to years 3 and 4 of the Plan, i.e. 2017 - 2018; **LT:** 'Long Term' refers to year 5 of the Plan, i.e. 2019

STRATEGIC PRIORITY	STRENGTHENING COMMUNITY GOVERNANCE				
Goal	<ul style="list-style-type: none"> To ensure effective and efficient governance arrangements that support good decision making, successful implementation of the regional agenda and accountability by all actors. 				
Strategic Objectives	Strategies	Principal Measures	Responsibility (Lead/Support)		Time Frame *
			Actor	Organ	
1. To enhance the practice of effective governance in the Community 2. To improve the efficiency of Community Organisations	GOV 3: Develop Governance Arrangements for Community Institutions	a. Develop and implement a governance arrangement for the Community Institutions to address: <ul style="list-style-type: none"> - Accountability of Institutions to Organs - Application of the performance framework of Community Strategic Plan for Institutions - Collaboration among Institutions, CCS - Use of tools e.g. MOUs, Service Agreements to support collaboration 	CCS Community Institutions	HGC Community Council	ST - 2015/2016
		b. Undertake the review of the Community Institutions to rationalize functions and enhance efficiency	CCS Community Institutions	HGC Community Council	ST - 2015/2016
3. To improve the rate of implementation of Community decisions and the CARICOM agenda	GOV 4: Strengthen Relationships and build Partnerships with IDPs	a. Implement annual schedule of engagements with existing and new development partners	CCS Member States Community Institutions	COFCOR Community Council	ST - LT
		b. Deepen initiatives for improved coordination and management of IDP resources	CCS Community Institutions CCA	Community Council	ST 2015/2016
	GOV 5: Develop and Agree on the Desired Governance Arrangements for the Future	a. undertake consultations and dialogue among Member States and Organs to develop a long term view of the integration for the Region	CCS CCA	HGC Community Council	MT - 2018

* **ST:** 'Short Term' refers to years 1 and 2 of the Plan i.e. 2015 - 2016; **MT:** 'Medium Term' refers to years 3 and 4 of the Plan, i.e. 2017 - 2018; **LT:** 'Long Term' refers to year 5 of the Plan, i.e. 2019

5.2 Enabling Implementation: HR, Budget, Operating Systems, Monitoring and Evaluation

Article 9 of the RTC provides general direction to Member States for faithful implementation of mandates viz. *“Member States shall take all appropriate measures, whether general or particular, to ensure the carrying out of obligations arising out of this Treaty or resulting from decisions taken by the Organs and Bodies of the Community”*. Nonetheless, implementation is perceived by many as slow and/or ineffective. In that regard, successful implementation of the plan of action set out in the Framework at 5.1 above, will require an enabling environment with a range of features.

These ‘success factors’ were highlighted throughout the stakeholder consultations in Member States, CARICOM Institutions, and the Secretariat as vital for good strategic management going forward. They include: human resource capacity and capability; sustained financing; efficient operating systems and effective monitoring and evaluation and reporting.

5.2.1 Human Resource Capacity and Capability

CARICOM’s Institutions and Organisations, as well as the Member States, are challenged to attract and retain the specialist human resources needed for the regional integration process. The cadre of international public servants is limited by the type of skills and competencies required and the competitive environment for these skills. The Region’s public service institutions, including the Secretariat itself, which have the major responsibility for implementation, are constrained in terms of compensation and terms and conditions of service.

In this context, over the planning period, attention will be given to building the capability to the existing cadre of officers through training and development. In addition, as the Plan is multi-sectoral and being implemented by multiple entities, a pooling/sharing of human resource expertise is feasible.

Key initiatives to build HR capacity and capability over the period may include:

- (a) Optimizing the resource of the CARICOM Ambassadors/Change Drivers and CARICOM experts;
- (b) Filling key vacancies at the Secretariat (as part of the reform of the Institution);

- (c) Development of a man-power plan and rationalising the staff positions at the Secretariat as part of the Organisation's reform;
- (d) Maximizing opportunities for on-the-job training for youth;
- (e) Providing scholarships programmes in areas of study related to regional integration;
- (f) Attracting technical expertise through cooperation with development partners;
- (g) Leveraging the resource of officers that have been trained in critical areas;
- (h) Developing mechanisms for recognition and reward (to retain talented officers);
- (i) Developing a performance management framework that allows for accountability, assessment and capacity building support of all the implementing entities involved in implementation of the Strategic Plan;
- (j) Continuous leadership development among all stakeholder groups involved in the implementation, but with special emphasis on Member States, the CCS, institutions, youth, and regional non-state partnering Organisations.

5.2.2 Sustained Financing

The budgeting of the Plan of Action (**Section 5.1**) is an important step for ensuring that sustained financing is available to enable effective implementation. However, the adequacy of funding for CARICOM's initiatives, both strategic (in this strategic plan) and recurrent, is paramount. Article 27 of the RTC highlights the importance of taking full account of the financial implications of decisions/mandates and avoiding 'unfunded mandates'. In the planning period, every effort will be made to ensure that there is good budgeting and management of budgets.

To that end, the following is recommended:

- (a) Revisit and institute the recommendations of the PMEGG (2005) and TWG on Governance (2007) on **autonomy of financing**, using an appropriate source e.g. percentage of revenues from intra-regional trade or intra-regional travel;
- (b) Consider the feasibility of a mechanism to involve the diaspora in funding specific initiatives;
- (c) Strengthen systems for good cost management, for example, sharing of services across implementing entities in Member States;

- (d) Use the strategic plan as the basis for negotiations with development partners, so that funding sourced in this way, can be targeted and more effective;
- (e) Use the review of the CARICOM Institutions to ascertain the overall cost of regional integration, as a basis for exploring opportunities to rationalize the CARICOM architecture and share resources for the benefit of the whole.

5.2.3 Establish a Robust Communications Infrastructure and Network

5.2.3.1 The Communications Network

The Four-Tier Communications Strategy being developed by the Secretariat emphasizes the critical importance of an effective network of persons across Member States. This extends to the CARICOM Institutions as well. Key stakeholders within the network would be the Secretary-General; Heads of Government and Senior Officers in Member States, including CARICOM Ambassadors/Change Drivers; Communications Units/Government Information/Communications personnel in Member States; the CARICOM Secretariat, in particular the Communications Unit; Community Institutions, in particular their Communications personnel; the CARICOM Youth Ambassadors; partners in the private sector and civil society; and media personnel.

From an operational perspective, the Four-Tier Strategy notes that all partners must be readied through, for example, training and development of their infrastructure to make their contribution as envisaged. Once effected, however, this will be an extraordinary network which can produce extraordinary results. Stakeholders during the consultations agreed that communication efforts must be carefully coordinated to optimize the investment made and the resources available; a role ascribed to the CCS and/or an oversight committee made up of the various partners.

The 'architects' must be given the time and space to develop the network and it is recommended that memorandum of understanding are used to support the relationships among the various partners.

5.2.3.2 The Communications Infrastructure

To support the operations of the communications network and the programme of work as envisaged, a robust communications infrastructure is essential. It is noted that the infrastructure must enable all levels of communication for the work of CARICOM, among other things; collaboration among work groups/partners; public education; advocacy; dialogue and decision-making as issues arise; public engagement/consultation in the policy process; monitoring and reporting; and archiving, data management and clearing house activities.

However, it is also noted that different partners will be at different stages of capacity, for example, as it relates to technology or bandwidth for internet based activities. The communications protocols will need to take account of these differences to ensure that there is equity. Where possible, specific action must be taken to encourage shared services and to strengthen and develop the infrastructure where this is needed.

'Mapping' the communications infrastructure will be important: i) to ensure that the implementation of the Communications Programme is aligned with the capacity available; and ii) with a goal to overall development of the infrastructure over time.

The main challenge over the planning period will be to ensure that sustained resources are available to fund the Communications Programme and the development and maintenance of the communications infrastructure. Efforts will be made to ensure that action taken is cost effective and where possible the relationship with the public sector, private sector and other partners is optimized to pool/access resources.

5.2.3.3 Building a Culture of Communication and Information Sharing Across Partners

The success of the public relations/public education/communications programme proposed above is premised upon the collaborative efforts of all partners adopting a culture of communications and sharing of information. To that end, it will be important to take specific action to develop the required culture.

For many, the implementing of a collaborative communications programme for CARICOM will be a new experience. In that regard, change management methodology can be applied to support this critical undertaking, so that all actors 'buy in' and commit to the goals, aspiration and

programme of work. Certainly, building the desired culture will take some time and sustained effort and where possible, the appropriate behaviors should be recognized and valued.

Of equal importance will be the need to develop and agree upon a set of principles and protocols that will govern how all partners interact and support team efforts and the sharing of information.

5.2.4 Efficient Operating Systems

Efficient operating systems are needed across all the implementing agencies of CARICOM for successful implementation of the Strategic Plan. In that regard, going forward, there will need to be agreement in principle on the arrangements, policies, procedures and practices with respect to:

- Internal and External Communications and Public Relations
 - Information, Education and Communications

‘Internal’ communications which will be the ‘lifeblood’ of multi-organisational implementation to ensure that all partners have access to information for decision-making and effective delivery of services. The standard operating procedures for external communications and public relations must also be developed and address communication and sharing of information with the public as well as local and international stakeholders and interest groups.
- Management Information Support/Data Management Systems

The management information support (MIS) system and infrastructure that must ‘feed’ all partners. The system must be robust and well protected while at the same time allow access by a wide range of stakeholders. The system must support complex functions including database management, storage and cataloguing of documents.
- Project Coordination and Management

This ‘system’ is essential since implementation of the Plan involves several Organisations working concurrently to achieve the shared deliverables and targets. There must be well-defined processes for developing, resourcing and evaluating work plans.
- Monitoring and Evaluation System

Building on the MIS outlined above, the M&E system must facilitate input of data and information from a range of sources including reports of implementing partners. The development of the M&E system will be guided by the M&E Framework in this Plan. Protocols, procedures and standardized templates must be developed to guide stakeholders contributing to the system or reporting on implementation of projects and programmes. Protocols for persons and Organisations wishing to access information from the system must also be developed.

5.2.5 Monitoring, Evaluation & Reporting

Monitoring, evaluation and reporting (M&E) are fundamental for proper strategic management that allows for adjustment of the framework for action in the Strategic Plan, over the planning period, to take account of changes in the environment. A strong M&E system will, among other things, ensure that progress is 'visible' to stakeholders and beneficiaries; that weaknesses are quickly identified and addressed; that targets are achievable; and that the Plan itself remains relevant to the needs of the Region.

The monitoring and evaluation framework for this Strategic Plan, outlined at **Chapter 6 (Section 6.2)**, adopted the **results based management approach**, further to the recommendations of stakeholders, viz.:

- (a) The desired results must be clear and articulated in terms of outputs, outcomes and impacts. Goals should be stated simply and link the Strategic Plan to the goals of the RTC. The results must be broken down into annual targets for tracking progress and reporting. This will allow for timely adjustment where needed;
- (b) The key performance indicators (KPIs) must be applicable across implementing Agencies (e.g. Ministries in Member States, Institutions, CCS) and these Agencies must have the capacity to collect, analyze and report data related to these indicators in keeping with well-defined protocols. In that regard, where possible, indicators which already exist, for example, in trade, agriculture or governance, will be used. KPIs should include those related to key result areas such as trade, agriculture and education; as well as those related to management such as governance arrangements, project management, and cost management;
- (c) The M&E system must be able to support managing performance across multiple implementing agencies (e.g. Ministries in Member States, Institutions, CCS), to create a relevant, shared 'scorecard' that allows each implementing Agency to report on the progress towards agreed targets;
- (d) Reporting, for example, the presentation of situational/outlook reports that are evidence informed, must be evident at meetings of Heads of Government and the Councils - a manageable reporting schedule is needed;

- (e) An assessment of the capacity of implementing agencies to conduct monitoring, evaluation and reporting functions must be undertaken, and any weaknesses addressed;
- (f) An independent monitoring and evaluation function is needed which may be facilitated by a relevant regional institution. In that regard, data collected and monitoring systems located in implementation agencies (Ministries in Member States, Institutions, CCS) must be auditable;
- (g) The annual Community Report, coordinated by the CARICOM Secretariat, should be based on the agreed targets within the Plan and include inputs from all organs, bodies, agencies and institutions. This Report must be timely, tabled each year at the Meeting of the Conference of Heads of Government by the Secretary-General, and well circulated to all stakeholder groups and the people of the Region.

5.3 Considerations for the Way Forward

Implementing the CARICOM Strategic Plan will be a considerable undertaking given the need to bring into alignment, the work of a wide range of institutions. The Plan is a bold step which can revolutionise the regional development 'infrastructure' and really move the CARICOM agenda forward. With this in mind, the following are important considerations for successful implementation.

1. **DEMAND FOR SERVICES FROM THE COMMUNITY** - Over the Plan period and beyond, it is anticipated that the demand for the services provided by CARICOM⁴¹ - for example research, capacity building, information, public education, legal advice, policy advice, and resource mobilisation - will intensify as Member States seek support in terms of critical skills and guidance to advance regional initiatives at the national level. In that regard, the services of CARICOM Institutions and especially of the CCS will be in high demand and will need to be accessible and available to Member States. This emphasizes the importance of strengthening these Institutions to respond to the needs of Community stakeholders.

⁴¹ See Section 2.4

In addition, the demand for 'new' services is also likely to increase given the changing needs of Member States in a highly dynamic global environment. Some examples of services that would be required⁴² include:

- ④ The facilitation of critical thinking through the promotion of 'Think Tank' Organisations and 'Centres of Excellence'.
- ④ Enabling creativity and innovation - e.g. through transforming the school system and tertiary institutions' curricula and instructional systems, as well as through specialized programmes.
- ④ Sharing of 'best fit' experiences between Member States and with third parties.
- ④ Promotion and facilitation of Public Private Partnership (PPP) between governments, private sector (local, regional and international), and civil society Organisations.
- ④ Database development and management and Information Sharing.
- ④ Quality Management.
- ④ Mediation/Conflict Management - between Member States, institutions, partners and citizens.
- ④ Advocacy for good governance, effective public sector management/public sector reform, and human rights.

Shifts in demand for services will need to be monitored regularly to ensure that needs are being met in keeping with the vision for reform of the Community. This level of monitoring will be made possible through the strengthening of the consultative process at the national level as envisaged in Strategic Priority 6. However, to respond effectively, given likely constraints in resources, new and innovative ways must be found to provide these services sustainably (which include ensuring access to funding). For example, i) greater cooperation among Institutions will optimise existing resources; and ii) developing the means to access key skills from the Diaspora.

⁴² Emerging from the national consultations in Member States

2. **MANAGING THE TRANSITION TO A NEW COLLABORATIVE WAY OF WORKING ACROSS MULTIPLE ENTITIES** - The transition to 'corporate' management across the Community will be a major plank of successful implementation of the Strategic Plan and the reform process in the Community. With that in mind, ensuring that the change management initiatives outlined in Chapter 7 are implemented, supported by adequate resources, is a critical factor for success. This period of transition will require time, patience and a willingness to work together among key stakeholders. Fortunately, the governance arrangements to be pursued in Strategic Priority 6 as well as the reform within the CCS will give structure to the transition process. It must be emphasized however, that CCS will be the 'hub' for the reform and must be *given the space* to arrange its programme of work to include this vital undertaking.

3. **PRINCIPLES OF IMPLEMENTATION** - Strategic, participatory management should be the hallmark of implementation as this approach addresses the widely acknowledged challenges of the regional integration 'decision making and implementation deficits'. This would equate to the following enabling principles:

- (a) A focus on set goals and targets with on-going research and scanning of the environment to enable adjustments as necessary;
- (b) Equitable access to beneficiaries of all Member States, thus extending the reach of the benefits of the Community;



Figure 6: PRINCIPLES OF IMPLEMENTATION

- (c) Differentiation with harmonization in terms of differentiating among the contributions required from, and benefits to devolve to each Member State, while at the same time harmonizing actions across Member States. In other words, it would not be necessary to have all actions take place in all Member States at once, given the realities of differing states of readiness. It can be agreed that implementation of specific aspects of the Plan may need to take place at different speeds in different Member States;
- (d) Resource sensitivity and thus functional cooperation and collaboration across community actors, including Member States and the Regional Institutions, to make the best use of skills, services and products, wherever these reside within the Community;
- (e) Transparency, openness, accountability facilitated by on-going, constant communication to ensure maximum participation of all stakeholders.

These principles must undergird the implementation of the Strategic Plan and, more generally, the initiatives of the Community, thereby giving life to the Core Values laid out in **Chapter 4 (Section 4.1.3)** viz. Unity/Togetherness, Equity, Integrity, People-centeredness, Performance-Driven/Results Focused, Good Governance and Good Environmental Management.

4. **STRATEGIC MANAGEMENT AND 'ROLLING THE PLAN'** - Fundamental to successful implementation of the Strategic Plan is a robust strategic management function within the Community. The function of coordinating implementation of the Strategic Plan across the Regional Integration Architecture (viz. CCS, Community Institutions, Member States and other partners) will be vested in the CCS, with the understanding that each agent will need to do its own operational planning in the context of the expert mandate that it is required to perform; in alignment with the overall strategic goals and targets the Community must achieve.

The strategic management function will include ongoing scanning of the environment, forecasting, strategic review, planning, coordination of and consultation with implementing agents, monitoring and reporting. The ongoing scanning and review will be important for 'rolling' the Strategic Plan forward each year over the planning period, as it informs the development of, and reporting on, annual work programmes for

implementing the strategic priorities; and enables regular reporting on progress including mid-term and end of term evaluations. Good strategic management is vital for ensuring that the Plan will remain relevant and responsive to changes in the environment over its five year life span.

5. **NEED FOR TECHNOLOGY SUPPORT** - Technology has been cited by many stakeholders as the 'game changer' for CARICOM. Certainly, appropriate technology will enable cost effective collaboration and coordination across Community Institutions, for example, with respect to information sharing, virtual teamwork and multi-agency management of projects. The opportunities for the use of technology must be fully realized, bearing in mind some constraint with resources. To support the integration of technology in implementation, an assessment and 'mapping' of the technology infrastructure across all Community Institutions will be a useful starting point for strengthening the overall system.

6. **MEMBER STATE ASSESSMENTS** - As a mechanism for improving services as well as for ensuring good implementation of regional initiatives at the national level, profiles/portfolios of Member States should be developed. The portfolios would track the progress of Member States with respect to key indicators for development and regional integration such as status of implementation of key mandates, capacity/readiness to implement regional decisions, shifts in the socioeconomic environment (positive and negative) affecting development, and regional programmes (from Community Institutions, IDPs) being implemented nationally.

The portfolio/profile will be a basis for providing 'customized' services to each Member State that will ultimately ensure that all stakeholders do benefit as envisioned from regional integration. These profiles will be a vital tool, providing rich data for good management, monitoring and reporting.

7. **ROLE OF CHANGE DRIVERS** - The corps of Change Drivers was initiated as part of the reform process, in the first instance to facilitate the development of the Community Strategic Plan. The mandate is now expanded, bearing in mind the vision for the reform of the Community, which has been made clearer by the Strategic Plan. The Change Drivers have proved themselves invaluable, providing a critical link with between the national and regional architecture. Going forward, it is likely that the role of the Change

Driver and the CARICOM Ambassador, as defined at Strategic Priority 6, will 'merge'. In some instances, this has already begun as some Change Drivers have created teams to support action at the national level.

Altogether, the Change Drivers must continue to play their vital role as it relates to mobilising the national community in the 'rolling' implementation, adjustment, monitoring and evaluation of the Strategic Plan; and the reform of the Community, over the Plan period.

8. **ROLE OF INSTITUTIONS** - As noted above, the Strategic Plan provides a framework for collaborative action for the range of Community Institutions. In that regard, *the Community institutions play a vital role as primary implementing agents for the Plan*, and therefore are essential to successful implementation.

Working towards common goals and outcomes presents a significant change to the way the work is done in the Community. Through the Secretary-General, opportunities for collaboration and dialogue have deepened. Going forward, the Secretary-General will continue to work with colleagues in the Community Institutions to develop the mechanisms for 'corporate' management of the Community, as outlined at Strategic Priority 6. It is noted that the Institutions will need the 'space' to, among other things: i) develop harmonized systems of operation and management as envisaged; ii) nurture mechanisms for working collaboratively; and iii) adopt a shared system for monitoring and evaluation.

9. **ROLE OF COMMISSIONS** - The CARICOM Commission on the Economy and the Regional Transport Commission are two key mechanisms that will continue to play a significant role over the Plan period in terms of guiding action as it relates to Strategic Priority 1. The role of these Commissions and similar mechanisms for planning, management and implementation of strategic initiatives must be well defined further to the governance arrangements laid out at Strategic Priority 6.
10. **OECS and CARICOM** - The OECS offers best practice examples for the wider CARICOM in a number of areas given the accelerated process of integration among these Member States. Over the Plan period, a deepening of the symbiotic relationship between the OECS and CARICOM is desired, beginning with enhanced collaboration between the Secretariats.

5.4 The Role of the CCS Going Forward

The role to be played by the CARICOM Secretariat is deemed vital for successful implementation and management of the Regional Integration Agenda. Reform of the Secretariat will prepare the organisation to fulfil its evolving mandate that will take it beyond administration to strategic management of the Community, and provide key services expressed by stakeholders, in collaboration with Community Institutions, where appropriate:

1. Strategic Management of the Community - Forecasting, Planning, Coordination, M&E and Reporting;
2. Community Governance, including regional consensus building, compliance, mediation;
3. Regional Public Policy Development including policy research and information dissemination, policy coherence and policy advocacy, research and technical advocacy, data and information management and technical advice;
4. Legal Assistance - Legal Drafting, Legal Leadership and Advice (to support Member States, the Principal Organs, Organs and Bodies, in collaboration with Institutions);
5. Servicing of Organs and Bodies; related meeting/conference management;
6. Public Education, Corporate Communications (including 'Brand' Management);
7. Resource Mobilisation;
8. Capacity Building/Support for Member States.

Table 2 (**pages 109-114**) outlines some of the key areas for development within the CCS to allow the Institution to take up its enhanced role going forward, in particular, as a coordinating mechanism for the Strategic Plan. These recommendations should guide the development of the Transition Plan for the CCS in the wider reform project, along with the more general considerations below:

- (a) **Creating the Desired Culture** - Perhaps the critical aspect of the reform process for the CCS will be bringing the desired culture into being. Building on its strong attributes of commitment and technical expertise, the CCS must seek to enhance its customer orientation, results orientation, and strategic outlook. A team based/collaborative culture must be developed. The desired culture must be supported by the practice of the core values, strengthened leadership of the Senior Management cadre, development of the

performance management system to take account of desired behaviours, the development of efficient supporting systems and enhancing the terms and conditions of work;

- (b) **Human Resource Management and Development** - This will be an area for immediate and comprehensive development for the CCS. Work must continue and accelerate to treat with recruitment and working conditions as well as retention and talent management. The CCS is severely challenged with the number of vacancies in key positions that remained unfilled. In addition, staff are leaving the Organisation at an unacceptable rate. Concerns with staff terms and conditions of work, training and development, job enrichment, and timely resolution of HR concerns are critical for improving staff morale. In addition, managers at the CCS must be strengthened to take on their HR responsibilities to enhance supervision, coaching, mentoring and staff motivation and improved performance management.

The reform of the Secretariat must be accompanied by a strategic HR plan which will involve:

- ⦿ Further development of the competency framework for the CCS, given the services and role for the Organisation going forward;
 - ⦿ Conduct of a work force analysis which will assess the current staff in relation to the complement, skills and competencies required. The work force analysis is informed by the competency framework being developed;
 - ⦿ Restructuring and realignment of departments taking account of the findings of the work force analysis;
 - ⦿ A strategic training and development plan to close gaps in skills required (outside of recruitment of new staff);
 - ⦿ Further development of HR related policies, procedures and practices (being undertaken by the HR Unit and the Human Resource Sub-Group of the Internal Change Team);
- (c) **Leadership Development** - In anticipation of the enhanced strategic role of the Executive Management team, the recent reconstitution of the Senior Management Committee (SMC) through the Office of the Deputy Secretary-General is welcomed. Initiatives to

further enhance the leadership role of senior managers in terms of operations management, as well as staff supervision and development are critical going forward. It is noted however, that the enhanced role of senior managers will be enabled by the strengthening of the work teams in the Directorates.

All managers, EMC and SMC, must have personal development plans which will inform the leadership development programme for the CCS. The competency framework developed for managers will guide this important initiative;

- (d) **Customer Care Orientation** - A deeper commitment to customer care in relation to the Member States and stakeholder must be a hallmark of a reformed CCS. Structures, systems and behaviours must be aligned to ensure that the services of the Secretariat are relevant and moreover, meet/surpass the expectations of clients and stakeholders. The development of country assessment/profiles will enable the envisaged new level of customer orientation and ensure that *services are linked to results*.

Another initiative recommended is to redesign the CCS offices in Barbados and Jamaica to serve as 'satellite offices'. This initiative coupled with others, such as the corps of CARICOM Ambassadors, can create a living presence of CARICOM in Member States. This satellite arrangement can also be used to bring services of the Community Institutions closer to Member States;

- (e) **Technology and re-engineering of systems and operating processes** - The need for technology supports raised at Section 5.3 above are mirrored for the CCS. The IT infrastructure is greatly outdated and therefore limited in the capacity to facilitate the range and improved level of services the CCS must provide to Member States. IT based solutions must be integrated into the operations of the Secretariat in a manner that would optimize efficiency and effectiveness. A significant investment is needed to upgrade the IT infrastructure of the CCS, but this is a critical success factor for reform of the organisation.

In addition, the CCS main business processes must be reviewed and, where needed, be re-engineered for improved efficiency. It is likely that some business processes are now obsolete while new ones are required. A business process review is a key initiative in the reform of the CCS.

TABLE 2: RECOMMENDATIONS FOR STRENGTHENING THE CARICOM SECRETARIAT⁴³

SERVICES	WHAT EXISTS (KEY ISSUES)	WHAT IS NEEDED	RECOMMENDATIONS
<p>Community Governance Regional Consensus Building Compliance Advocacy Mediation/Conflict Management</p>	<ul style="list-style-type: none"> • The CCS provides administrative support for governance within the Community • There is limited coordination across the Regional Integration Architecture • Advocacy on Community issues led by Heads of Government and the SG • Statements made in response to major incidents • The Secretariat has taken on the role as election observers • The SG provides good offices disputes settlement on request 	<ul style="list-style-type: none"> • Enhance ‘corporate’ management of the Community to optimise the services and benefits to Member States, as well as cost efficiency • Enhance leadership role in terms of policy, strategy and high level engagement of Member States, Community Institutions, and stakeholders/ partners • Proactive advocacy positions and statements • Timely advocacy and mediation of issues affecting MS and between MS • Clear guidance on the limits of the SG and CCS as it relates to internal conflict in Member States • Formalise role as election observers 	<ul style="list-style-type: none"> a. Strengthen and restructure the Office of the Secretary-General to provide strategic leadership for the Community including the reform process b. Establish a leadership development programme that includes the most senior leadership c. Strengthen the Senior Management cadre (SMC) for operational leadership d. Address vacancies at the Executive and Senior Management levels e. Strengthening of Management to allow SG/EMC space to enhance advocacy and mediation roles f. Strengthen press/communications function within the Secretariat g. Strengthen Directorates as needed to enable advocacy function

⁴³ These recommendations should guide the development of the transition plan for the CARICOM Secretariat in the wider reform process

SERVICES	WHAT EXISTS (KEY ISSUES)	WHAT IS NEEDED	RECOMMENDATIONS
<p>Strategic Management Forecasting, Planning, Coordination, M&E and Reporting Project/Programme Planning and Management</p>	<ul style="list-style-type: none"> • Development of sector based policy and programmes, though this can be ‘siloeed’ with limited engagement across Directorates and Organs • Project/programme management is a distributed function across departments. ‘Centralized’ project management with respect to some donor funded initiatives through RMTA. 	<ul style="list-style-type: none"> • Build capacity to undertake strategic management for the Community - act as a ‘hub’/coordinating mechanism for planning, implementation and M&E • Enhance CCS internal strategic management • Enhance resource mobilisation to advance the regional development agenda • Strengthen project management skills across the CCS 	<ol style="list-style-type: none"> a. Strengthen and restructure the Office of the Secretary-General to undertake Community strategic management, support of the Change Drivers/CARICOM Ambassadors b. Strengthen and restructure the Offices of the members of the EMC to facilitate their role as advocates for implementation of the Strategic Plan c. Strengthen Strategic Management Unit within ODSG for enhanced internal strategic management d. Project Management, M&E training for managers, technical officers and administrative support staff e. Establish project management office within the ODSG to treat with management of large donor funded projects f. Review and development of business processes for strategic management e.g. research (scanning), corporate planning, M&E, goal management g. Upgrade of IT systems to enable strategic management, project management

SERVICES	WHAT EXISTS (KEY ISSUES)	WHAT IS NEEDED	RECOMMENDATIONS
<p>Policy Management Regional Public Policy Development and Management Policy Research and Information Dissemination Policy Coherence Compliance Coordination and Harmonization</p>	<ul style="list-style-type: none"> • Development of sector based policy and programmes, though this can be ‘siloesd’ with limited engagement across Directorates and Organs. Limited policy coherence • Policy initiatives tend to be reactive rather than proactive. There is limited opportunity for policy work to respond to forecasting, trend analysis, and research in light of work load, shortage of staff in key positions • Limited public education and compliance functions to support policy implementation 	<ul style="list-style-type: none"> • Enhance policy research • Enhance engagement of MS and stakeholders in the policy process as well as follow up to facilitate implementation and compliance • Enhance public education • A customer centred approach 	<ol style="list-style-type: none"> a. Strengthen and restructure the Office of the Secretary-General to provide strategic leadership viz. strategic management, monitoring and reporting and compliance b. Review and development of business processes and systems to support policy management c. Human resources development in key skills e.g. policy research, stakeholder management, customer care
<p>Legal and Technical Advisory Support Research Legal Assistance - Legal Drafting, Legal Leadership and Advice Technical Advice</p>	<ul style="list-style-type: none"> • Comprehensive legal support to stakeholders though affected by some vacancies. Given current trends, demand for legal support is likely to increase • Technical support to Member States and stakeholders constrained by limited capacity and resources for research. Several vacancies in technical positions. Key areas such as transportation and energy are severely under-resourced 	<ul style="list-style-type: none"> • Enhance legal services to facilitate national implementation of mandates, harmonization, further movement towards rules-based Community • Strengthen technical advisory function allowing for research, monitoring, stakeholder engagement • Strengthen critical departments • Develop cross Directorate work teams and inter-agency work teams (enhanced relationships with Institutions) 	<ol style="list-style-type: none"> a. Recruit technical officers to address key vacancies b. Review and strengthen business process including research, M&E c. Partner with Community Institutions to undertake agreed on research agenda d. Establish, as feasible, a customer service ‘desk’ for each Directorate to facilitate routine request for information from stakeholders (repurpose of clerical staff, freeing technical staff for more strategic tasks)

SERVICES	WHAT EXISTS (KEY ISSUES)	WHAT IS NEEDED	RECOMMENDATIONS
Public Education/ Communication/ Information Management	<ul style="list-style-type: none"> ⦿ The CCS provides press releases, information via its website, some social media interaction, archiving of Community history, information and events ⦿ Some databases in place ⦿ There are resource constraints - human, technical - that limit the delivery of consistent service ⦿ Limited engagement of the general public 	<ul style="list-style-type: none"> ⦿ Consistent timely public education and information reporting ⦿ Enhance internal communication to enable collaboration, consultation, implementation and M&E ⦿ Expand capacity for database development and management 	<ul style="list-style-type: none"> a. Strengthen Communications Unit to implement the Communications Strategy b. Strengthen communications functions within the OSG c. Upgrade of technology infrastructure to support internal and external communications, information management d. Develop communication skills/function of managers and officers across all departments e. Develop skills for management of information systems across departments f. Establish, as feasible, a customer service 'desk' for each Directorate to facilitate routine request for information from stakeholders (repurpose of clerical staff, freeing technical staff for more strategic tasks) g. Strengthen/Develop linkages with communication and information management function in other Community Institutions

SERVICES	WHAT EXISTS (KEY ISSUES)	WHAT IS NEEDED	RECOMMENDATIONS
Servicing the Organs Servicing of Organs and Bodies; Meetings/Conference Management	<ul style="list-style-type: none"> • The Secretariat facilitates in excess of 200 meetings per year; • There are efforts to enhance the use of technology for meetings and other fora to facilitate the work of the Organs and Bodies; • There are efforts to improve the management of meetings; • Establishing of new Commissions and Committees as well as proposed governance arrangements will increase demand for servicing the Community. 	<ul style="list-style-type: none"> • Improve systems for servicing the Community. 	<ol style="list-style-type: none"> a. Review the conference and meetings business processes with a view to eliminating existing gaps as envisioned with Strategic Priority 6 b. Review and strengthen the Conference Services Department and recruit needed personnel.
Capacity Building to Support Implementation in Member States	<ul style="list-style-type: none"> • Capacity building initiatives for Member States are undertaken by all Directorates as needed, to support implementation of programmes • Some centralization of capacity building with TASU 	<ul style="list-style-type: none"> • Coordinated approach to capacity building across Offices and Directorates, and with Community Institutions to optimize resources and sustainability • Customized capacity building based on assessment of Member States' needs (Country Assessment described above) 	<ol style="list-style-type: none"> a. Build capacity to undertake and maintain country assessments b. Review of business processes in relation to capacity building services to allow for collaboration and coordination across departments

SERVICES	WHAT EXISTS (KEY ISSUES)	WHAT IS NEEDED	RECOMMENDATIONS
Resource Mobilisation	<ul style="list-style-type: none"> ⦿ Negotiation, acquisition and management of donor funds ⦿ Some challenges with management of donor funds, with steps being taken to correct 	<ul style="list-style-type: none"> ⦿ Strengthen capacity to initiate and facilitate mobilisation of resources from traditional and new partners, in collaboration with Member States, Community Institutions ⦿ Improved management of donor resources 	<ul style="list-style-type: none"> a. Strengthen and restructure the Office of the Deputy Secretary-General to undertake resource mobilisation

SECTION D

- ① How Do We Know We Have Arrived?

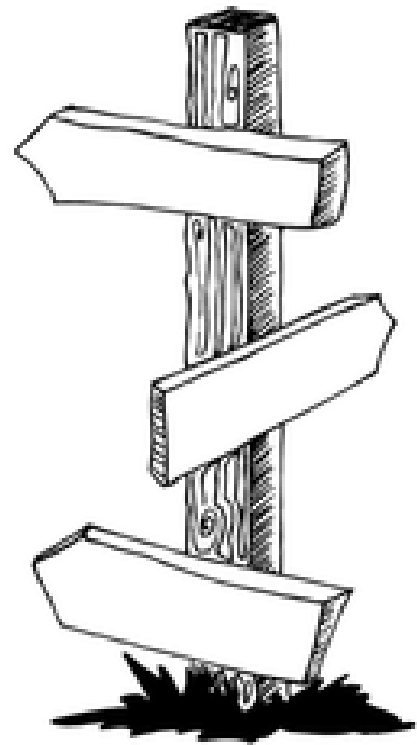

6.0 THE STRATEGIC MANAGEMENT FRAMEWORK

6.1 Approaches to Monitoring and Evaluation

The development and implementation of the Strategic Plan presents an opportunity for Heads of Government to share, on an ongoing basis, the value, importance and benefits and challenges of regional integration with the people of the Region. It must be emphasised that the people of the Region are both contributors to, and beneficiaries of, regional integration. In this regard, there must be regular reporting against agreed performance indicators to the Organs of the Community, as well as popularising the results to the widest possible cross section of the CARICOM population.

Monitoring and measurement mechanisms are required to show: i) what the indicators of the progress of the change will be over specified periods; and ii) how monitoring and reporting will work across multiple implementing agents. In that regard, it should be noted that monitoring and measurement indicators are to deal with both the development objective (e.g. food and nutrition security for the people of the Region, especially the poor) and the regional integration objective (e.g. Harmonisation of production and manufacturing across Member States; and common services). Further, the mechanism for monitoring the implementation of the Strategic Plan must work across multiple implementing agents.

The development of a monitoring and evaluation framework for the Strategic Plan draws on two models - Results-Based Management (RBM) and the System of Indicators for Regional Integration (SIRI).

6.1.1 Results-Based Management

The results-based management (RBM) approach is promoted internationally by several development Organisations including the United Nations, as a preferred method for strategic planning and management. The model has several attributes that make it particularly relevant for use in CARICOM.

- *It is results-driven - RBM requires clear definition of expected results and in this way places the beneficiary at the centre of programme design, development and delivery.*

There is a focus on who has benefited, and how they have benefitted, in relation to the vision and set goals.

- *It is evidence based* - RBM emphasizes performance monitoring and reporting against set goals and targets. Results must be defined along with performance measures that can track the progress of achieving the results. Vigilant monitoring ensures that there is timely data for information and decision-making among stakeholders.
- *Results are developmental* - RBM requires planners and stakeholders to describe results beyond programme outputs to expected outcomes and impacts for the beneficiary groups. In that regard, RBM starts with the 'end in mind'; and stakeholders are encouraged to consider how the programme will improve the quality of life for the target population.
- *It anticipates collaboration* - RBM anticipates that services to the target group will be delivered through partnership among multiple stakeholders, working together to achieve agreed upon goal(s). The Model's planning design allows for this 'co-delivery'.

RBM means, in collaboration with stakeholders⁴⁴:

- Identifying **beneficiaries** and designing interventions to meet their needs.
- Defining **realistic expected results**, based on appropriate analysis.
- **Managing and monitoring** progress towards results and resources consumed, with the use of appropriate measurable **performance indicators**.
- **Identifying and managing risks**, while bearing in mind expected results and the necessary resources.
- **Reporting on results achieved** and the resources involved.
- Increasing knowledge by **learning lessons** and integrating them into decisions and possible reformulation.
- **Disseminating and discussing the results** in a transparent and iterative way.

The RBM model encourages planners and policy developers to make a continual link between daily operations and outputs and development objectives, that is, the desired improvements in the quality of life of beneficiaries and the society. With budgets tied to these 'outcomes' and

⁴⁴ McKay, B, TDV Global

'impacts', the expectation is that expenditure will be more effective and produce tangible results that positively affect the lives of persons.

A clear advantage of the RBM model is its 'logic', along a Results Chain as shown in **Figure 7**. The model gives a framework for '*drilling down*' from the strategic objectives to the specific expected *outputs, outcomes and impacts* from the delivery of services and action taken in pursuit of the strategic priorities. With the model, specific (or expected) outputs and related outcomes and impacts are also described, making the link between the outputs and a tangible difference in the lives of beneficiaries (impacts). This kind of detailed, integrated planning is not typical of the traditional strategic planning and makes the RBM approach a strong one.

Figure 7: THE RBM LOGIC - THE RESULTS CHAIN⁴⁵

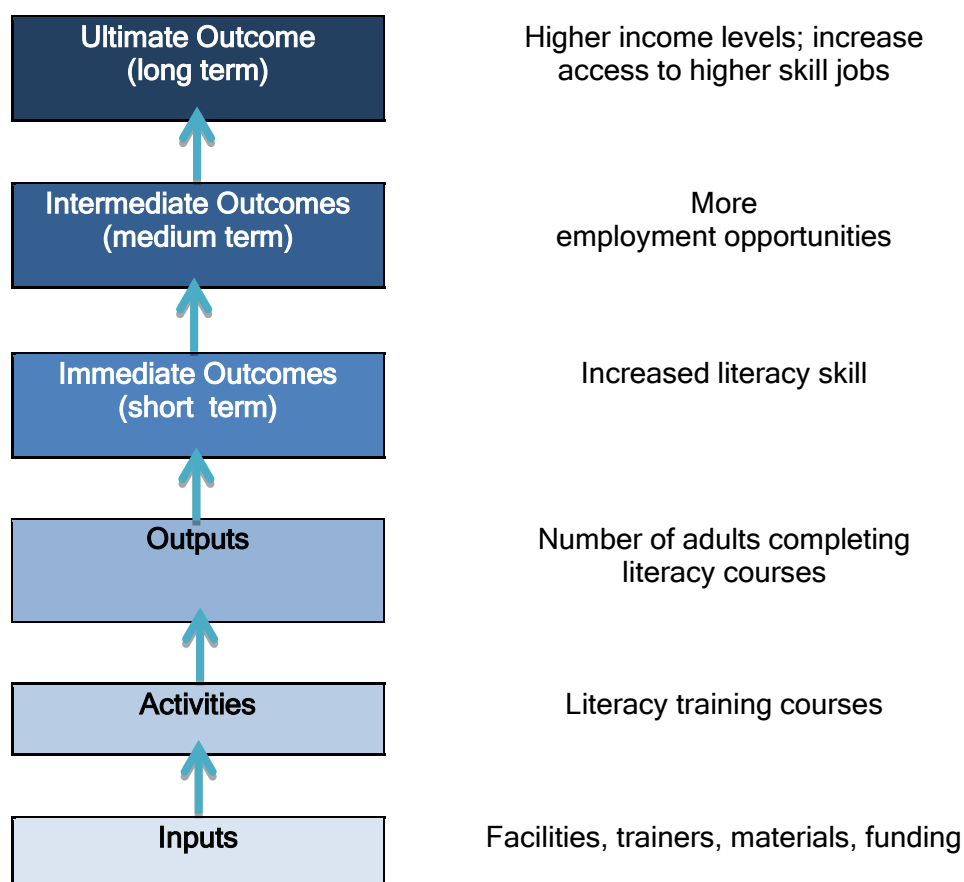

⁴⁵ Ibid

The CARICOM Secretariat has already begun to use RBM, and the development of the M&E Framework for the Strategic Plan builds on these initiatives.

6.1.2 Measuring Integration – The SIRI Model

Consistent monitoring and measuring of regional integration has been an elusive necessity.

Fortunately, a model, the SIRI, is being developed by the United Nations University, Institute for Comparative Regional Integration Studies.

The SIRI is a recent initiative that has had significant attention from two of its chief proponents and researchers, De Lombaerde and Van Langenhove. Below is a summary of the conceptual and methodological issues with the implementation of a SIRI as presented by Lombaerde and Van Langenhove.⁴⁶

- ⦿ Regional Organisations are good candidates for the construction of a SIRI because they want to monitor their own policies.
- ⦿ For cost-efficiency and political reasons, it would be prudent to pool resources for the construction of a SIRI. Three types of institutions that might participate in the development and implementation of a SIRI are multilateral institutions (UN, the World Bank, WTO), regional institutions, and the academic sector.
- ⦿ A SIRI will only be successful if it is a joint product between “users” and “producers”, taking into account input from all relevant stakeholders.
- ⦿ Because of the nature of the phenomenon, a SIRI should be able to monitor the integration process.
- ⦿ A SIRI should be sufficiently flexible to consider processes that are characterized by a tendency towards integration, but allow for phases of stagnation or even temporary disintegration.

⁴⁶ De Lombaerde & Langenhove

- ④ Indicators in a SIRI should reflect the specific characteristics of the integration process.
- ④ A SIRI should be able to reflect expressions of both “positive” and “negative” integration (Tinbergen, 1954). “Negative” integration refers to the elimination of barriers; “positive” integration refers to the formulation of common policies.
- ④ A SIRI can be built to decide upon the relevant level(s) of analysis - group, country or Region, or it can be built to monitor the participation of individual countries/regions in the integration schemes (individualised effects, policy implementation).
- ④ Once the coverage and limits of a SIRI are established, its variables should be organized systematically according to disciplinary fields (political, social, cultural, economic, etc.); policy areas (trade, investment, migration, competition, agriculture, industry, infrastructure, legal cooperation, etc.), or on a functional basis, like in the input-output approach. Integration is then implicitly seen as a process where some variables act as inputs, some as outputs, while others characterize the process. The advantage of this approach is the emphasis on the output (effects) of integration; from a welfare and development point-of-view, which is what it is all about.
- ④ The evaluation of integration policies and their implementation is an essential part of any SIRI. This requires the incorporation of indicators of policy implementation and effects of regional integration.
- ④ The assessment of the developmental impact of regional integration processes and policies could be done by incorporating regional development and (social) spending indicators in the SIRI.
- ④ Adequate monitoring tools for regional integration processes would allow better (regional) policy design and implementation, better scrutiny and participation by all stakeholders and affected groups and individuals, as well as more in-depth academic analysis of these complex social transformation processes.

Lombaerde and Van Langenhove conclude with a warning that the attempt to implement a SIRI will only have a chance to succeed if conceptual, technical, political, institutional and organisational aspects are simultaneously addressed.⁴⁷

6.2 Developing the Monitoring and Evaluation Framework for the Strategic Plan

Using these two approaches, the Monitoring and Evaluation Framework will establish a 'scorecard' for tracking implementation of the Strategic Plan, bearing in mind the desired outcomes viz. *Strong Economic Growth and Reduction in Poverty and Unemployment, Improved Quality of Life, Reduced Environmental Vulnerability, and an Integrated Community with Equity for All.*

The Framework will then be used to develop a Monitoring and Evaluation System for the Community.

Given, the range of implementing agents involved in the implementation of the Strategic Plan, there will be a diverse number of sector specific indicators that would need to be included in the Monitoring and Evaluation System. **Table 3** overleaf, presents an example of *key* outcome indicators that can be used to track the goals and objectives with respect to Strategic Priority 1 and 2. It should be noted that the set of indicators is intended to be comprehensive but not onerous, and where possible, build on existing development indicators to ensure that there is capacity among implementing agents to collect the necessary data.

It is noted that the OECS is well advanced in the development of a monitoring and evaluation framework for economic integration which provides a good benchmark for the wider CARICOM. Bearing in mind the work already underway in the OECS, the goal would be to develop a RBM/SIRI model for CARICOM from which an M&E Framework would be developed for this Plan.

⁴⁷ De Lombaerde & Van Langenhove, p. 27

Table 3: EXAMPLE OF OUTPUT AND OUTCOME INDICATORS FOR M&E OF THE STRATEGIC PLAN

STRATEGIC PRIORITY	SAMPLE OF INDICATORS	RECOMMENDED DISAGGREGATION
Building Economic Resilience <i>GOAL</i> <i>To engender sustainable growth of the economies of Member States</i>	<u>Output Indicators</u> Rate of implementation of the CSME No. of persons, businesses accessing CSME arrangements Rate of harmonization No. of fora held with private sector No. of investment promotion events (<i>No. of businesses participating, No. of positive responses</i>) No. of new businesses in target sectors	Member State Member State, gender, age Member State, type of legislation/policy Member State, type of business, size of business Member State, type of business, size of business
	<u>Outcome Indicators</u> GDP capita Debt to GDP ratio Ease of Doing Business/Global Competitiveness Rating % of regional trade (to total trade) Growth of new businesses Employment rate Agriculture Indicators (trade, production, food security) % contribution of Renewable Energy Cost of energy No. of persons/volume of goods moved via intra-regional transportation Compliance with international agreements	Member State Member State Member State Member State Type of business, gender, age Member State, gender, age, rural/urban distribution Member State, gender Member State, type of business Member State Member State, Cost, time Member State

STRATEGIC PRIORITY	SAMPLE OF INDICATORS	RECOMMENDED DISAGGREGATION
Building Social Resilience <i>GOAL</i> <i>To ensure sustainable human and social development in the Region with reduced levels of poverty and equitable access by vulnerable groups and significant improvement of citizen security by facilitating a safe, just and free Community</i>	<u>Output indicators</u> No. of training and development initiatives completed No. of persons participating in training and development programmes No. of public sector mainstreaming initiatives completed No. of health initiatives completed No. of persons, organisations accessing health initiatives No. of security, justice initiatives completed No. of persons, organisations participating in security, justice initiatives	Member State Member State, Gender, age, rural/urban Member State Member State Member State, Gender, age, rural/urban Member State Member State, Gender, age, rural/urban
	<u>Outcome Indicators</u> Rate of access to primary, secondary, tertiary education Rate of attrition among students - primary, secondary, tertiary levels Skills gaps in key developmental areas Emigration, immigration rate of skilled persons Youth development indicators Morbidity rates Mortality rates Crime and security indicators	Member State, gender, age Member State, gender, age Member State Member State, gender, age Member State Member State, gender, age Member State, gender, age Member State, gender, age

6.3 Developing a System of Regional Indicators for CARICOM

Developing the SIRI model for CARICOM builds on the Monitoring and Evaluation Framework for the Strategic Plan, ensuring the appropriate indicators are derived to track implementation of the RTC itself. **Table 4** below, lists key indicators/variables which may be adopted by CARICOM, based on work being done by the United Nations University.

Table 4: SAMPLE INDICATORS FOR DEVELOPING A SIRI MODEL

CATEGORY	SUB-CATEGORIES
I. Actors	<ul style="list-style-type: none"> ▪ Number of integration units involved (countries, regions, organisations, institutions) ▪ Number and quality of actors in the decision-making process ▪ Level of activity of the actors ▪ Actors' opinions and perceptions (survey results) ▪ Overlapping memberships
II. Structural Factors	<ul style="list-style-type: none"> ▪ Proximity of the actors (e.g. geographical, cultural) ▪ Structural complementarities ▪ Structural asymmetries ▪ Historical patterns of cooperation, integration and ▪ Conflict
III. Institutionalisation	<ul style="list-style-type: none"> ▪ Number of treaties and agreements ▪ Contents of treaties and agreements ▪ Time frames of treaties and agreements ▪ Institution building - No. of Institutions, effectiveness of institutions, overlapping portfolios ▪ Arrangements on common policies and policy coordination ▪ Gradualism, exemptions and differential treatments
IV. Implementation	<ul style="list-style-type: none"> ▪ Status of implementation of general treaties ▪ Status of implementation of specific agreements ▪ Degree of accomplishment of convergence criteria
V. Effects	<ul style="list-style-type: none"> ▪ Human development ▪ Economic growth ▪ Trade ▪ Migration ▪ Capital flows
VI. Interdependence	<ul style="list-style-type: none"> ▪ Mobility of persons ▪ Political interdependence (e.g. existence of common policy variables, <i>de facto</i> coordination of policies, occurrence of conflicts, tensions) ▪ Economic interdependence (e.g. trade, capital flows, correlation of activity levels, symmetry of shocks) ▪ Information and knowledge flows

Guidance from the experts developing SIRI models notes the complexity of the task, particularly as it relates to the difficulty in isolating the effects of integration from those of other phenomena. An alternative would be to consider the short term effects to address this problem. However, given the perceived advantages of regional integration for the small states of CARICOM, it is important to develop the means for tracking the longer term value of the RI process on national development in Member States.

Altogether, assessing the extent to which the RTC has been implemented and the concomitant benefits to Member States is imperative.

SECTION E

- ① **How Do We Remain In a State of Renewal?**

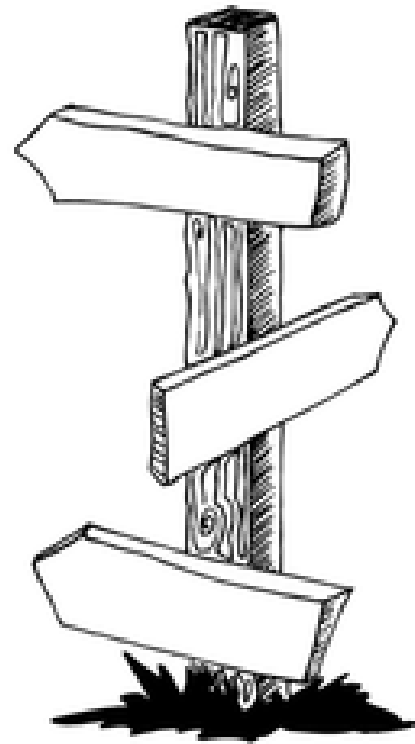

7.0 THE CHANGE MANAGEMENT FRAMEWORK

7.1 Introduction

The priorities for regional integration proposed in the Community's Strategic Plan 2015 - 2019 require strategic mindset shifts in ways of thinking and relating, on the part of Community Organs, Bodies, Institutions, the CCS, Member States and non-state partners, who must work in concert to implement the Plan and deliver the desired results. In that regard, there must be specific steps taken to take account of anticipated actions and reactions, and build capacity and capability for change among the diverse stakeholders.

As indicated in the earlier Sections of the Plan, the guiding question for the change management agenda is: *How does the Region unify and rally around the creative talents of its people, foster innovation and implement mechanisms to unleash the growth potential for its Members, all whilst ensuring the most vulnerable are not neglected?*

The regional integration policy response is contained in the Resilience Model and the range of actions to be pursued to accelerate development in the Region. While the Plan gives clarity on the development path to be taken to achieve the goals and objectives of economic turnaround for sustainable human development, there is an imperative to ensure that the institutional and behavioural changes needed to ensure success are well defined and managed. This calls for an accompanying Change Management Strategy that will underpin the implementation of the Community's Strategic Plan. For example, in a targeted way, the Change Management Strategy must support the strategic priorities, in particular the 'driver' priority areas related to *Strengthening the CARICOM Identity and Spirit of Community* and *Strengthening Community Governance* (see Figure 8 overleaf).

FIGURE 8: THE DESIRED STATE FOR THE COMMUNITY

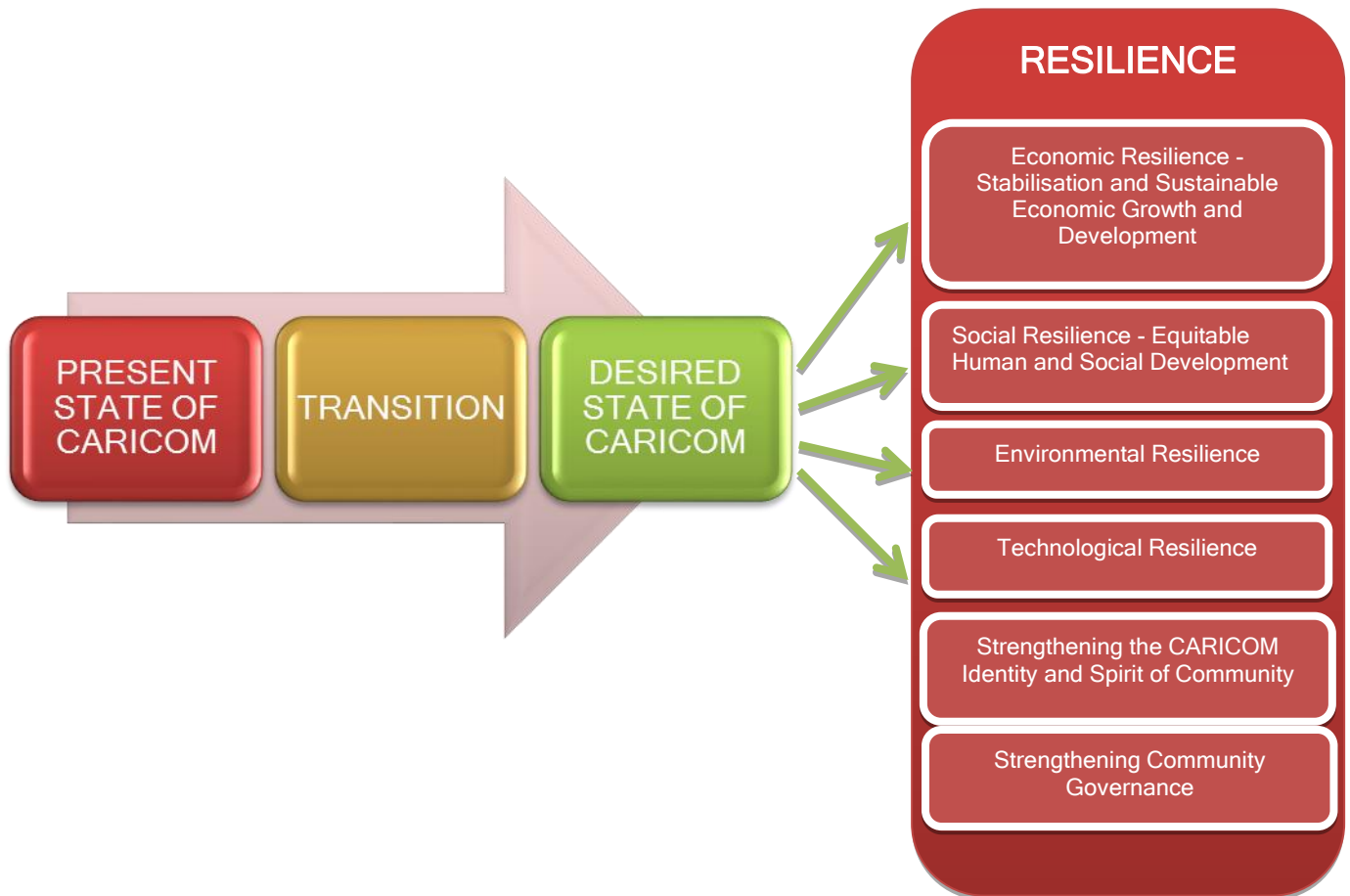

In view of the stated purpose, the change management framework which follows outlines the approach and steps to be taken to effect the institutional, organisational, and behavioural change needed for successful implementation of the Strategic Plan. This involves, among other things, determining how the leadership of the Community's political, administrative cadres (state actors), as well as non-state actors such as the private sector, civil society, and international partners, will position themselves to implement the Strategic Plan to the equitable benefit of all the Community Members, so as to achieve 'win-win' outcomes over time.

A goal of change management is to have the Member States, Organs, Institutions, the CCS, and wider CARICOM citizenry adopt/adapt the Plan's new vision, mission, core values, as well as new ways of working and relating and, to that end, treat with the range of reactions to the

changes which will come with implementing the agreed upon priorities articulated in the Plan. Ultimately there must be 'buy in', commitment and sustained active participation by all involved.

7.2 Charting the Path of Implementation – Developing the Community Change Management Strategy

Managing institutional and behavioural change among such varied stakeholders that includes geographical and demographically diverse 'sovereign' Member States, autonomous Community Institutions and civil society partners, calls for keen attention to articulated and perceived interpretations of the priorities in the Community's Strategic Plan. Addressing the perceived interpretations, especially in terms of the behavioural aspects, is a key success factor for successful implementation and moreover, successful change and transformation of the Community as envisaged.

7.2.1 A Model for Charting the Change Process in Plan Implementation

Figure 9 overleaf, which outlines the “Four ‘Quadrants’ of Change Management”, shows the relationship between the institutional, organisational and people (behavioural) sides of change.

The change process for CARICOM has begun with a review/refocusing of strategy and a new strategic direction with the Community's Strategic Plan (Quadrant 1 in **Figure 9**). The new direction charted has and must continue to stimulate dialogue among primary and secondary stakeholders and the citizenry at large throughout the Community for ultimately, implementing the strategic priorities of the Plan has to be measured in terms of the *impact on people* (quadrants 2 and 4 of **Figure 9**). For example, what are the likely effects of Plan implementation on nationals in the various Member States who long for 'hassle free' travel and wish to acquire skills certificate to secure employment or ply their trade in other parts of the Community. What is the new Community culture needed for the turnaround of the economies and to lift living standards? How can the political and professional leadership cadres be motivated to commit to a new way of thinking about regional integration and working to make outcomes as equitable as possible?

In addition, there is the need to identify the systems, structure, policies and processes (Quadrant 3 in **Figure 9**) that must change to enable the effective decision-making, problem solving, and implementation of strategy, and to put these in place.

FIGURE 9: THE FOUR QUADRANTS OF CHANGE MANAGEMENT

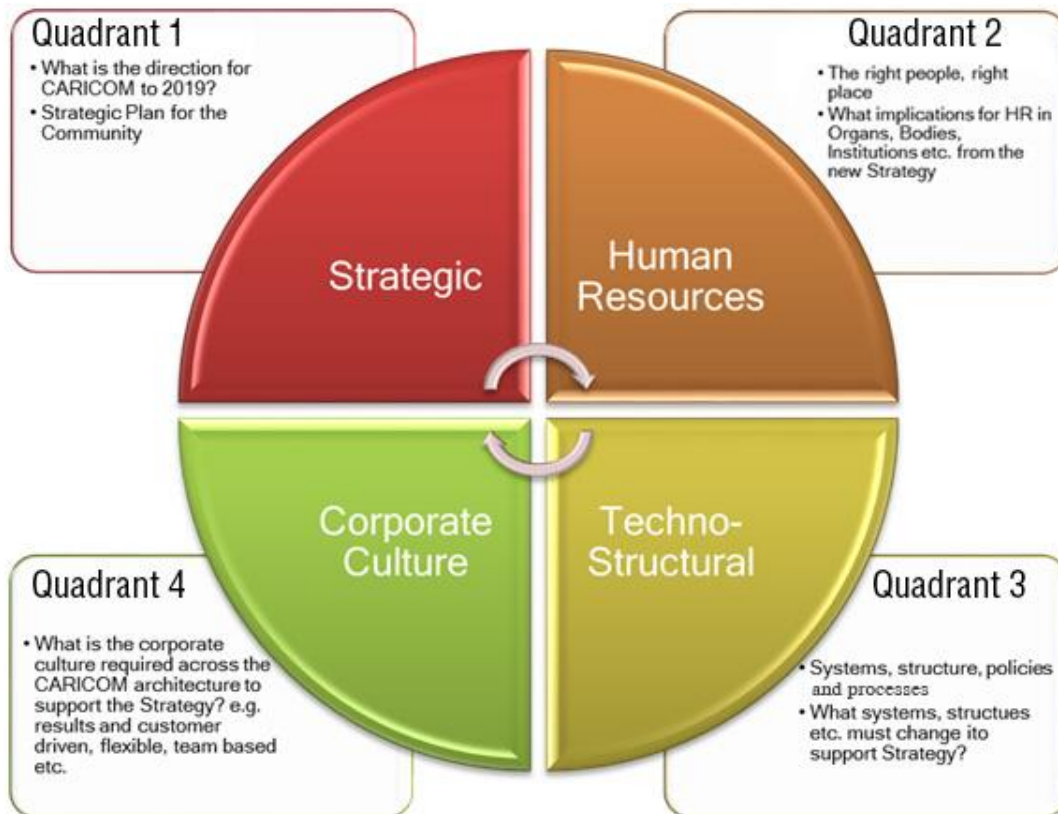

Source: Adapted from Cummings & Worley, 2002

Figure 10 overleaf, which is based on *Burke-Litwin of Organisational Performance and Change (2002)*, lays out a simple framework for the change process for CARICOM in support of Plan implementation. Moving systematically through these stages, using the four quadrants at **Figure 9** to ensure both sides of the change are addressed, will help to ensure effective, long-term, and sustainable results.

At each step, change enabling activities and steps are introduced, pre-tested and communicated in ways that enable Community stakeholders to let go of any existing inappropriate attitudes and behaviours and develop any new ones that would facilitate the transformation of the Community. This attitudinal and behavioural change is critical as the *'people factor'* is now widely acknowledged as perhaps 'the foremost success factor' in achieving social transformation.

FIGURE 10: THE ORGANISATIONAL CHANGE PROCESS

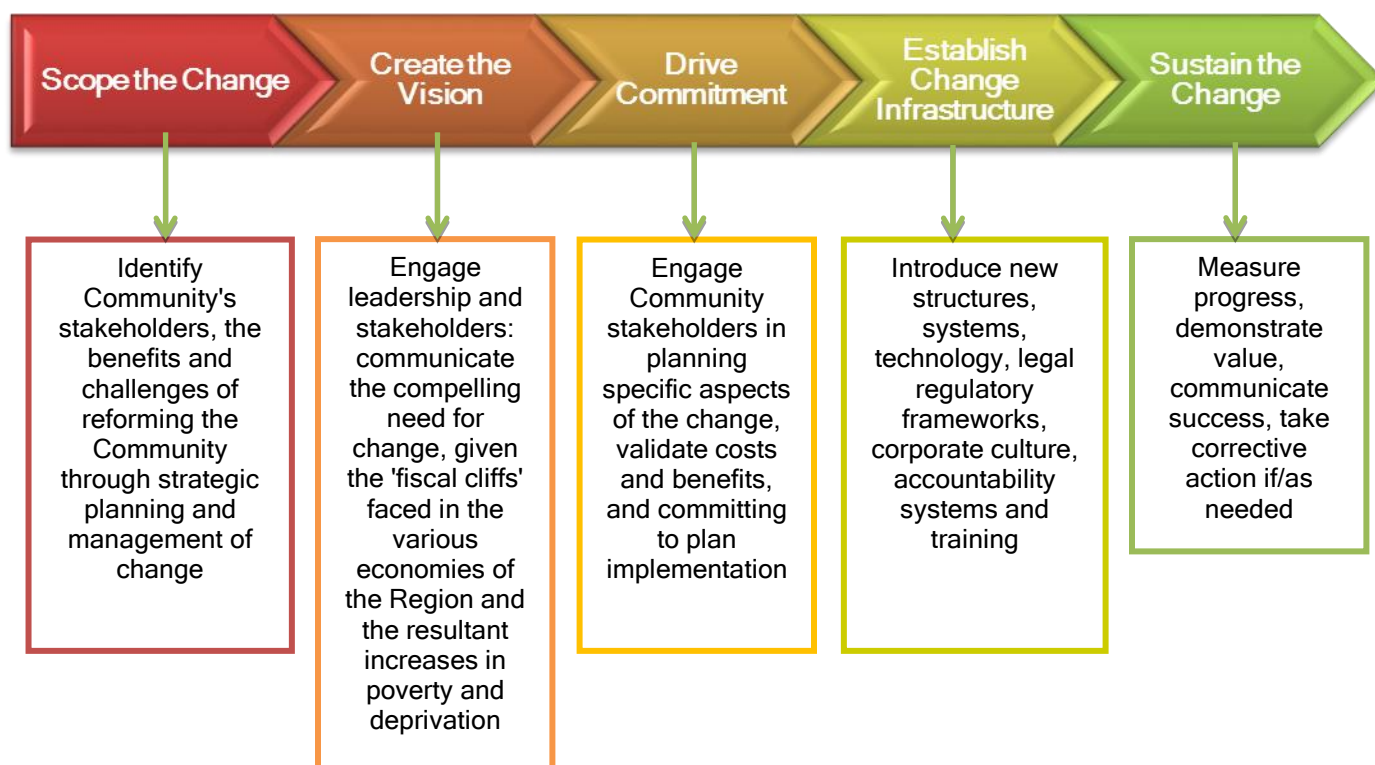

The Burke-Litwin Model identifies the key elements of the Organisational Change Process (see **Figure 10**), along with the critical transactional factors that impact the successful adoption of the planned change, especially in public service institutions, for example:

1. The public policy environment - directions and mandates; legal regulatory factors;
2. The governance strategy employed by the CARICOM Organs, Bodies and Institutions, as well as at the level of the Member States;
3. Leadership and Management within the CARICOM Secretariat and the wider Regional Integration Architecture driving the implementation of the Community's Strategic Plan;

4. The performance measurement system to monitor and evaluate the implementation process.

In **Table 5** overleaf, the Burke-Litwin Model is used to outline a Change Management Framework to support the Strategic Plan.

TABLE 5: A CHANGE MANAGEMENT FRAMEWORK TO SUPPORT IMPLEMENTATION OF THE COMMUNITY STRATEGIC PLAN

Dimensions of Model	Key Questions	Application of Model to Community Plan Implementation	Change Outcomes
<p>1. Environment</p>	<p>a. What are the key intra and extra regional drivers of the changes to be derived from implementing the Community's Strategic Plan?</p> <p>b. How are these stakeholders likely to impact on the Plan implementation process?</p>	<ul style="list-style-type: none"> • In pursuit of implementing the resilience driven priorities in the Community's Strategic Plan, firmly agree on the role of the Conference of Heads of Government, the Community Council, the Organs, the Bodies, the Secretariat and the Community Institutions in partnership with regional and extra regional partnering stakeholders. 	<ul style="list-style-type: none"> • Region wide acknowledgement of the responsibility of the diverse range of stakeholders to lead and manage the implementation of the Community's Strategic Plan, both within the CARICOM 'construct' (including at the national level) and extra-regionally
<p>2. Vision, Mission, Core Values and Strategy</p>	<p>a. Have the Community stakeholders, especially the political and professional cadres embraced the Vision, Mission and Core Values upon which the Plan's resilience driven priorities are based?</p> <p>b. What are responses to these Vision, Mission and Core Values by the Community's citizenry at large, as well as extra regional stakeholders?</p>	<ul style="list-style-type: none"> • Continue the regional stakeholder dialogue that contributed to formulating the Plan to ensure that the Plan implementation strategy and process emanate from the Community's state and non-state actors, with the latter emphasizing the pivotal role of the private sector and civil society, including the youth bodies. 	<ul style="list-style-type: none"> • Popular participation and civic engagement in all phases of Plan implementation

Dimensions of Model	Key Questions	Application of Model to Community Plan Implementation	Change Outcomes
<p>3. Leadership</p>	<p>a. Who would be widely recognized as being accountable for effective Plan implementation?</p> <p>b. Who must consistently model the appropriate styles of decision-making and decision-taking to achieve the implementation targets and outcomes set out in the Plan?</p> <p>c. What is the style of leadership and management suitable for decision-making and decision-taking in such a geographically and demographically diverse Community?</p> <p>d. What must be the role of Community Institutions, public service bodies, private sector and civil society in implementing the Plan within the Member States?</p> <p>e. What role is seen for extra regional bodies such as IDPs and IFIs</p>	<ul style="list-style-type: none"> • Define the role of Community leader/manager cadres viz. the Conference of Heads of Government, Community Council, the Organs, the Bodies, the Secretariat, Member States and Community Institutions, private sector, civil society • Assessment of the current capacity/capability of the diverse leadership across the Community to support the Plan implementation 	<ul style="list-style-type: none"> ⦿ Highly mobilised and committed cadre of leaders in the Community (including the political and technical directorate, private sector and civil society) capable of demonstrating seriousness of purpose in mobilising the populations in the Member States, and able to measure implementation outcomes along set timelines.

Dimensions of Model	Key Questions	Application of Model to Community Plan Implementation	Change Outcomes
<p>4. Community Political and Institutional Culture</p>	<p>a. What are the overt and covert rules, values, customs, and modalities of decision-making/decision-taking that would promote the 'CARICOM Identity' needed to bind the populations in the Member States together and engender a sustained sense of belonging and urgency to pursue Plan implementation?</p>	<ul style="list-style-type: none"> • The agreement on mechanisms to bring the desired culture of results driven implementation that is adaptive to country level development needs, and equitable 	<ul style="list-style-type: none"> • A forged CARICOM Identity and Civilization characterized as open to ongoing dialogue and constructive conflict handling throughout the challenging periods of Plan implementation. • Appropriate unifying 'symbols'/events to reignite pride in the Community; to serve as a source of energy and drive to implement creatively, the resilience driven priorities in the Plan. • Positioning the CARICOM regional integration movement in the hearts and minds of the people of the Community, through continual advocacy of CARICOM as pivotal to the economic recovery and growth and the human development of the peoples of the Community.



Dimensions of Model	Key Questions	Application of Model to Community Plan Implementation	Change Outcomes
5. Structure/Systems	a. How are implementation roles, functions and people re-arranged within the CARICOM 'construct', viz. the Conference of Heads of Government, Community Council, the Organs, the Bodies and the Secretariat and Community Institutions, in partnership with regional and extra regional partnering stakeholders? b. What are the key decision-making, communication, and management control mechanisms that can be tracked and assessed for their effectiveness during Plan implementation?	<ul style="list-style-type: none"> • Process map roles, responsibilities and accountabilities of the various state and non-state actors in the Plan implementation • Develop the appropriate 'corporate' operational systems to support collaborative implementation and strategic management 	<ul style="list-style-type: none"> ⦿ A 'fit for purpose' institutional framework that process maps the role, responsibility, accountability and sanctioning arrangements for Plan implementation.
6. Performance Tracking and Measurement	a. What clear cut performance criteria exist to allow for tracking of the diverse stakeholder performance in all phases of Plan implementation? What would be the performance standards and measures in use?	<ul style="list-style-type: none"> • Develop and institute the M&E system to track and evaluate Plan implementation 	<ul style="list-style-type: none"> ⦿ Compliance reporting mechanisms linked to set performance criteria and indicators and the mapped processes for Plan implementation.

CONCLUSION

The Plan as designed, lays out the reasons for concerted action and a radical process of reform for the Community at this time and, in response, outlines the model for economic, social, environmental and technological resilience, strengthened unity and governance reform.

As well, the Plan outlines the implementation imperatives, strategic and change management modalities with the necessary monitoring, measurement, and evaluation frameworks. The critical action now is 'buy in' and onward movement.

APPENDICES

Appendix 1	Overview of the Planning Process
Appendix 2	List of Community Institutions and Associate Institutions
Appendix 3	Snapshot of Key Achievements of the Community
Appendix 4	Strengths, Weaknesses, Opportunities, Threats (SWOT) Analysis for the Community

APPENDIX 1: OVERVIEW OF THE PLANNING PROCESS

Figure A overleaf depicts 'The House of Change' noting that the Strategic Plan is an impetus for the reform of CARICOM. As shown, the strategic planning process was designed around five (5) building blocks viz. i) strategic review and analysis - where are we now?; ii) strategic framework - where do we wish to be?; iii) strategic implementation - what will get us where we wish to be?; iv) strategic monitoring and evaluation - how will we know we have arrived?; and v) strategic management - how we will sustain transformation?.

This exploratory framework and the methodology for the planning process were informed by the following seven (7) Pillars:

1. driven by leadership commitment (foundation element);
2. results based;
3. human focused;
4. knowledge management;
5. resource and risk sensitive;
6. implementation driven; and
7. stakeholder driven.

Of particular note is Pillar 6, 'Implementation Driven'. Bearing in mind the mandate of the Heads of Government, the planning process was designed to imbed implementation from the very onset and to that end, this process had the following as primary characteristics:

- (i) it built on previous strategic initiatives and current programmes underway;
- (ii) it involved wide consultation across stakeholders, bearing in mind their vision for the Community;
- (iii) it emphasized prioritization and management of results in the interest of beneficiaries who are themselves contributors, to be taken over the five year planning period; and
- (iv) it sought to clarify roles and responsibilities in implementation of the Strategic Plan.

Indeed, all pillars were applied throughout the planning process to ensure that the Strategic Plan represents the aspirations of stakeholders and the best opportunity for successful transformation for the Community (see Figure A, overleaf).

Figure A: 'THE HOUSE OF CHANGE': STEPS IN THE STRATEGIC PLANNING PROCESS

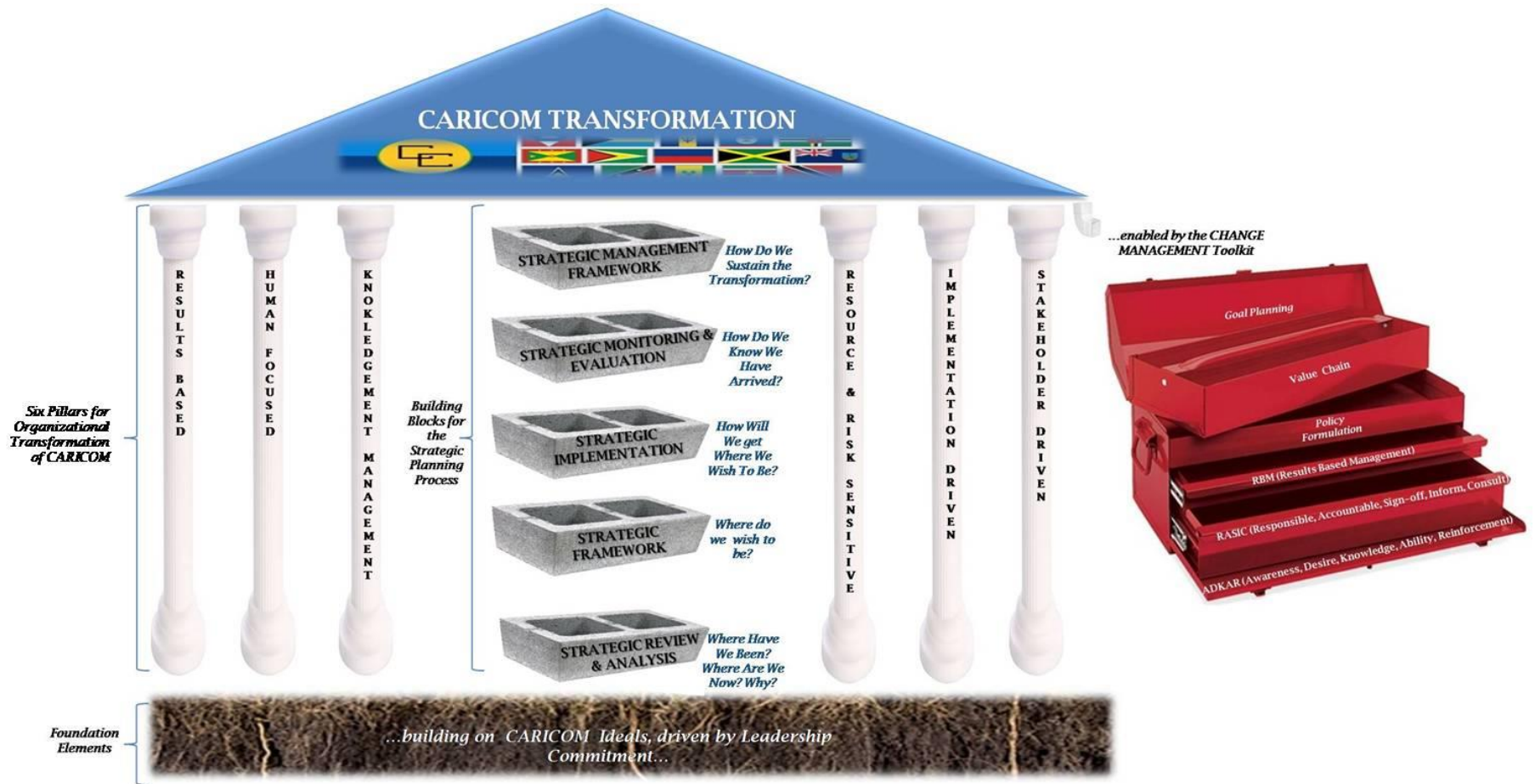

The preparation of the 'house' - the transformed CARICOM - continues, guided by the Plan, which outlines the range of institutional developments to be pursued in terms of structures, systems, skills and behaviours, to be facilitated through the Change Management Framework (outlined at Chapter 7).

THE PLANNING METHODOLOGY

Further to the framework for planning adopted, approaches were used that were grounded in the knowledge base that the Community had built to date and in the prospects for the future held by the various stakeholders. The following data sources were used:

1. Desk research and review of literature. This included a survey of previous documentation generated for and by CARICOM and other international and regional institutions. In addition, there was a review of literature both on CARICOM and on international issues impacting CARICOM which informed an understanding of the resources available as well as the strengths, weaknesses, opportunities and threats attendant upon the CARICOM environment. This activity addressed the principles of being knowledge intensive, resource and risk sensitive and would give some sense of leadership commitment and of the stakeholder base. Commentaries on CARICOM recorded in the popular print and broadcast media as well as on social media were also examined;
2. National Consultations responded largely to the principles of being human focused and stakeholder driven;
3. Key informants, some individuals who had studied and written on the Community or who had played key roles in the Community were also consulted. This also addressed the principles of being knowledge intensive and stakeholder driven;
4. A CARICOM Telesurvey was undertaken. The Telesurvey provided a measurement of public perception and awareness of CARICOM in Member States and Associate Members, as well as the perspectives on the priorities for the Community. The Telesurvey responded to the principles of being human focused and stakeholder driven. The survey used the most accessible means of communication to reach the public of

Member States. The survey targeted a sample of 4000 persons and eventually reached 3,996 persons;

5. A youth online survey was designed and conducted by the corps of CARICOM Youth Ambassadors (CYAs) as a contribution to the planning process and also responded to and demonstrated the principles of human focused and stakeholder driven. The youth online survey reached out to a most important sub-population of the Community, those targeted to be primary contributors to and beneficiaries of CARICOM development.

The primary focus in examining findings from all data sources was on: the vision for the Caribbean Community; in light of the vision, the strategic priorities for regional integration in serving sustainable development of the Member States; the requirements for successful implementation of these priorities; the means of measuring implementation; and as a consequence, measuring the progress towards regional integration and sustainable development.

Delimitations

The data collection process sought to respond to the imperative to target a narrow range of specified outcomes within specified timeframes, focusing on a few practical and achievable goals, while at the same time, capture as far as possible, the vision and approaches articulated by citizens of the Community. These two views - that of the decision makers and that upon whom the decisions impact - are not always consistent. The view that emerged as dominant is presented in this Plan.

Key Limitations

The mandate to derive a 'narrow range of outcomes' presented a challenge for the planning process, given the need to; (i) be inclusive in a diverse Community; and (ii) take account of all the factors that impact the narrow range of outcomes.

Time presented the next major challenge for the planning process. In that regard, while the process did reach a number of stakeholders and Community nationals with the support of the Change Drivers, there were some key informants that were not available during the time frame, given the limited time in each Member State. In addition, more of the people of the Community

may have been able to participate had there been the resources to enable same. In addition, time did not allow a 'recall' with participants in the Member States for validation of the inputs of the Plan. This gap will be addressed through the Change Drivers facilitating this feedback/exchange with the stakeholders in terms of sharing the Plan.

SUMMARY OF FINDINGS FROM DATA SOURCES

Data Source 1: Desk Research and Review of Literature

This includes a review of a range of regional studies, policies and strategic documents, national and regional development plans and national budgets. The research and review revealed:

- (i) That both substantive and institutional issues of regional import had already been identified by and for Heads of Government;
- (ii) That various approaches to addressing the issues had also been repeatedly identified. The need therefore was to relentlessly pursue implementation of the agreed measures to address the issues;
- (iii) Some common, core issues which could be considered as priorities or key results. These issues are also noted key result areas in the Revised Treaty and appear in some form in the national budgets of most Member States. Groundwork has already been laid regionally, so prioritizing them will lead to building on what already exists.

The following findings with respect to core priorities were identified:

- (a) Agriculture, in particular food and nutrition security;
- (b) Crime and Security;
- (c) Energy Security;
- (d) Intra-regional Transport;
- (e) Environment and Climate Change;
- (f) Economic Growth and Development;
- (g) Youth; Education and Training; Sports;
- (h) Health;
- (i) ICT; and
- (j) Services.

With respect to the institutional environment, the following priorities were also identified:

- (i) A strengthened governance 'infrastructure' which facilitates accelerated and effective implementation of CARICOM mandates. This would include the priorities identified in this Strategic Plan;
- (ii) Developing and maintaining fora/mechanisms for engagement of stakeholder groups (Youth, Private Sector, NGO Community etc.) in all aspects of the policy process;
- (iii) Clarity of roles and responsibilities, as well as improved dialogue and collaboration among the implementing agents across CARICOM (i.e. CARICOM Secretariat, Institutions, Ministries in Member States);
- (iv) An effective mechanism for sustainable funding of the work of CARICOM;
- (v) Strong, consistent, relevant communication that informs and engages the people of the Region of the work of CARICOM, and the vision for and benefits of regional integration;
- (vi) Strengthening the CARICOM Secretariat and other implementing agencies, ensuring adequate resources are in place to optimally fulfil their roles;
- (vii) A robust monitoring and evaluation system that allows and facilitates good accountability and managing performance across multiple implementing Agencies; and
- (viii) Strengthening the information and communications infrastructure to facilitate good governance, cooperation among stakeholders and effective management of the programme of work for CARICOM.

Data Source 2: National Consultations

National consultations were conducted in all 15 Member States and in two Associate Members. They were piloted in Barbados in June 2013 and continued over a four month period from August - November 2013. National Consultations were organized by Change Drivers in each country and among the stakeholders consulted were: Prime Ministers/Premiers and members of their Cabinets, Leaders of the Opposition, Government Ministries and Departments, the Private Sector, Civil Society Organisations, including Non-Governmental, Community Based and Religious Organisations, Trade Unions, the Mass Media, Youth and the Diplomatic Corps. Additionally, staff of regional institutions were consulted in Member States where they are based and staff of the CARICOM Secretariat were similarly consulted in a series of sessions over a two day period in December 2013.

The findings from each consultation were captured and collated to produce a regional pictogram as shown at **Figure B** overleaf.

This regional pictogram captures the recommended priorities for action along with supporting action. The priorities which emerged from the National Consultations included:

1. (Building Awareness of) the CARICOM Agenda;
2. Education;
3. Agriculture;
4. Free Movement;
5. Implementation;
6. Integration;
7. Economic Recovery;
8. Youth;
9. Transport; and
10. Governance.

FIGURE B: REGIONAL 'PICTOGRAM' OF PRIORITIES BASED ON NATIONAL CONSULTATIONS

KEY PRIORITIES	SUCCESS FACTORS	SUCCESS FACTORS	SUCCESS FACTORS	SUCCESS FACTORS	SUCCESS FACTORS	SUCCESS FACTORS	SUCCESS FACTORS	SUCCESS FACTORS
CARICOM AGENDA	 REBRAND	 COMMUNICATION & PUBLIC EDUCATION	 FOCUS ON WORKABLE INTEGRATION STRATEGIES	 IMPLEMENT DECISIONS AND ACTIONS	 BETTER COORDINATION OF ACTIVITIES AND IMPACTS	 BUILD CAPACITY WITH TECHNICAL ASSISTANCE	 PROVIDE LEADERSHIP	 SET GOALS & TARGETS
EDUCATION	 BUILD CAPACITY FOR THE FUTURE	 REVIEW CXC CURRICULUM TO INCLUDE REGIONAL STUDIES	 INCREASE INFORMATION FLOWS AT ELEMENTARY & SECONDARY SCHOOLS	 INVEST MORE IN ON-LINE LEARNING & TECHNOLOGY	 YOUTH DEVELOPMENT AWAY FROM CRIME	 PUBLIC EDUCATION	 HARMONIZE QUALIFICATIONS AT TERTIARY LEVELS	 INCREASE OPPORTUNITIES FOR EXCHANGE PROGRAMS
AGRICULTURE	 INCREASE FOOD PRODUCTION FOR FOOD SECURITY	 CREATE EMPLOYMENT WITH NEW JOBS	 IMPROVE REGIONAL TRADE	 ENCOURAGE HEALTHY LIFESTYLES	 DOWNSTREAM PRODUCTION & PROCESSING	 ECONOMIC RECOVERY THROUGH AGRICULTURE	 FOCUS ON LAND & ENVIRONMENTAL ISSUES	 USE TECHNOLOGY FOR RESEARCH & DEVELOPMENT
FREE MOVEMENT	 REMEDY THE CHALLENGES OF REGIONAL TRANSPORTATION	 FOCUS ON SOCIAL INTEGRATION	 TRAIN IMMIGRATION STAFF SPECIFICALLY ON CUSTOMER SERVICE & FREE MOVEMENT LEGISLATION	 HARMONIZE & IMPLEMENT SKILLS CERTIFICATION REGIME	 FULL IMPLEMENTATION OF THE FREE MOVEMENT LEGISLATION	 USE PUBLIC EDUCATION TO ENLIGHTEN CITIZENS OF THE FREE MOVEMENT AGREEMENT	 INCREASE TRADE IN GOODS & SERVICES	 REMOVE BARRIERS TO THE MOVEMENT OF GOODS, SERVICES, PEOPLE & CAPITAL
IMPLEMENTATION	 BRING ALL STAKEHOLDERS ON BOARD	 SET GOALS & TARGETS	 IMPLEMENT DECISIONS ALREADY TAKEN	 DEVELOP POLICY INSTRUMENTS	 BUILD THE HUMAN CAPACITY NECESSARY FOR IMPLEMENTATION	 HARMONIZE LAWS AND REGULATIONS	 ENSURE MEASUREMENT TOOLS ARE IDENTIFIED	 LEGISLATE SANCTIONS FOR NON-IMPLEMENTATION
ECONOMIC GROWTH & DEVELOPMENT	 BOOST FOREIGN & LOCAL TRADE	 AGRICULTURE	 IMPROVE EMPLOYMENT SITUATION IN THE REGION	 CRIME & SECURITY	 BUILD CAPACITY IN THE HUMAN CAPITAL	 FOCUS ON THE CHALLENGES OF REGIONAL TRANSPORTATION	 SHARE SERVICES TO REDUCE THE COST OF GOVERNING	 FOCUS ON THE GOVERNANCE PERSPECTIVE
INTEGRATION	 IMPROVE NETWORKING & COMMUNICATION	 CONTINUE THE PROMOTION OF FREE MOVEMENT	 FOCUS ON SOCIAL INTEGRATION	 INVEST IN MORE INTER-REGIONAL TRADING	 FIX THE CHALLENGES OF REGIONAL TRANSPORTATION	 HARMONIZE OUR STRUCTURES & SYSTEMS	 YOUTH ENTERTAINMENT & SPORTS WILL ENHANCE REGIONALISM	 RESTRUCTURED ORGANS & INSTITUTIONS
YOUTH	 COMMUNICATION THROUGH SOCIAL MEDIA	 YOUTH EMPOWERMENT & PARTICIPATION IN GOVERNANCE	 TRAINING & SKILLS DEVELOPMENT	 JOB CREATION & EMPLOYMENT	 EDUCATION	 TECHNOLOGY	 YOUTH & CULTURE	 MIGRATION & BRAIN DRAIN
TRANSPORTATION	 REDUCE THE COST OF TRAVEL IN THE REGION	 MOVEMENT OF PEOPLE, GOODS & SERVICES	 FOCUS ON ALTERNATIVE TRANSPORT	 TRANSPORTATION IMPORTANT FOR TOURISM	 BOOST INTEGRATION	 EASE CHALLENGES OF TRADING	 FIX PRESENT INTER-REGIONAL TRANSPORT SYSTEM	 ECONOMIC RECOVERY
GOVERNANCE	 IMPROVE THE POLITICS AND EXCLUDE POLITICAL WILL BY CEEDING LEVELS OF SOVEREIGNTY	 MEANINGFUL COMMUNICATION & COLLABORATION AMONG HEADS	 VISIONING & GOAL MANAGEMENT	 PROVIDE GREAT LEADERSHIP	 BUILD RELATIONSHIPS ESPECIALLY WITH THE YOUTHS	 IMPLEMENT DECISIONS TAKEN IN A TIMELY MANNER	 ACCOUNTABILITY	 BUILD CAPACITY AMONG THE YOUTHS

Data Source 3: Key Informants

Community citizens who had played a key role in CARICOM or who had studied and written on CARICOM, were interviewed for their unique perspectives. A synopsis of the views of key informants is set out below:

- (a) Promote the value of 'pooled sovereignty';
- (b) Focus on a few key priorities - food, energy, transport; do a few things that are visible and measurable, and have high impact;
- (c) Federation, full integration, presents the solution for the Community. Begin with a few states if needed and allow others to come on board;
- (d) Address governance arrangements and get the Community organs to function more effectively;
- (e) Address energy competitiveness and, in that regard, treat with the cost of doing business and with the cost of production;
- (f) Understand and pay attention to the process of domestic implementation of Community agreements viz. enactment, execution and enforcement;
- (g) Take account of the fact that implementation depends on the national ability to reform determined by the state-level politics and state-level capacity; and
- (h) Pay attention to the pivotal role of bureaucratic elites - Permanent Secretaries/Advisers of Ministries - that have significant influence on implementation in Member States than commonly acknowledged; and in that regard, the need to win the buy-in and commitment of this important group of stakeholders.

Data Source 4: CARICOM Telesurvey

The Telesurvey yielded the following key findings: Ninety per cent (90%) of CARICOM citizens knew of the existence of the Community with Jamaica and Montserrat demonstrating the highest level of awareness (100%). Of the sample surveyed, 75% were aware of CARICOM projects and 60% indicated the projects had a positive impact on their country. Thirty-four per cent (34%) felt that the projects benefited the right people and addressed the needs of the country.

The key priorities for CARICOM identified in the survey were as follows:

- (a) Health;
- (b) Education ;
- (c) Agriculture/Food/Nutrition Security;
- (d) Crime and Security;
- (e) Youth Development;
- (f) Economic Recovery;
- (g) Growth and Employment Training; and
- (h) Broadband and Network Access.

Citizens surveyed saw the Secretariat as the key level at which CARICOM decisions should be taken and as the leading body to ensure decisions taken were implemented. Heads of Government were seen as having the next level of responsibility for the taking and implementation of decisions (35.6%) and Ministers of Government (18%) were seen as having the third level of responsibility for decision taking and implementing. Given that the margin of error of the survey is 1.5%, it can be concluded that whatever obtains in reality, the average CARICOM citizen rests responsibility for decision-making and implementation in the Community with the CARICOM Secretariat.

Data Source 5: Youth On-Line Survey

The online survey engaged youth across the fifteen (15) Member States and the five (5) Associate Members. It is particularly interesting to note from the responses the continuing belief in the value of regional integration among youth. When asked to share a one word vision for the Community, it was described as “United/Harmonious” - 43%; “Quality of Life”; “Respected, Powerful”; “Progressive and Sustainable”; “Equity”; and “Dynamic”.

As important, the priorities for the Community identified by young persons were:

- ⦿ Agriculture, Food Security;
- ⦿ Economic Recovery & Growth;
- ⦿ Regional Unity;
- ⦿ Crime and Security;
- ⦿ Intra-regional Transport; and
- ⦿ Youth Development.

APPENDIX 2: COMMUNITY INSTITUTIONS AND ASSOCIATE INSTITUTIONS

COMMUNITY INSTITUTIONS			
INSTITUTIONS			COMMENTS
1.	CAHFSA	Caribbean Agricultural Health and Food Safety Agency	As per Decision of the Twenty-First Inter-Sessional Meeting of the Conference of Heads of Government (March 2010, Dominica).
2.	CARDI	Caribbean Agricultural Research and Development Institute	As per Article 21 of the Revised Treaty.
3.	CASSOS	Caribbean Aviation Safety and Security Oversight System	As per Decision of the Twenty-Ninth Regular Meeting of the Conference of Heads of Government (July 2008, Antigua and Barbuda).
4.	CARICAD	Caribbean Centre for Development Administration	As per Article 21 of the Revised Treaty.
5.	CCCCC	Caribbean Community Climate Change Centre	As per Decision of the Thirteenth Inter-Sessional Meeting of the Conference of Heads of Government (February 2002, Belize).
6.	CDEMA	Caribbean Disaster Emergency Management Agency	As per Article 21 of the Revised Treaty (Formerly CDERA).
7.	CXC	Caribbean Examinations Council	Formalised by Decision of the Twentieth Inter-Sessional Meeting of the Conference of Heads of Government (March 2009, Belize).
8.	CIMH	Caribbean Institute for Meteorology and Hydrology	As per Article 21 of the Revised Treaty. (Formerly CMI).
9.	CKLNA	Caribbean Knowledge Learning Network Agency	As per the Decision of the Twenty-First Inter-Sessional Meeting of the Conference of Heads of Government (March 2010, Dominica).
10.	CMO	Caribbean Meteorological Organisation	As per Article 21 of the Revised Treaty.
11.	CARPHA	Caribbean Public Health Agency	As per Decision of the Twenty-First Inter-Sessional Meeting of the Conference of Heads of Government (March 2010, Dominica).
12.	CRFM	Caribbean Regional Fisheries Mechanism	As per Decision of the Twenty-Fourth Regular Meeting of the Conference of Heads of Government (July 2003, Jamaica).
13.	CTU	Caribbean Telecommunications Union	Formalised by Decision of the Thirty-Fourth Regular Meeting of the Conference of Heads of Government (July 2013, Trinidad and Tobago).

COMMUNITY INSTITUTIONS (Cont'd)			
INSTITUTIONS			COMMENTS
14.	CCC	CARICOM Competition Commission	As per Articles 171 - 174 of the Revised Treaty.
15.	CDF	CARICOM Development Fund	As per Article 158 of the Revised Treaty and the Agreement Relating to the Operations of the CDF.
16.	CARICOM IMPACS	CARICOM Implementation Agency for Crime and Security	As per the Twenty-Sixth Regular Meeting of the Conference of Heads of Government (July 2005, Saint Lucia).
17.	CROSQ	CARICOM Regional Organisation for Standards and Quality	Pursuant to Article 67 of the Revised Treaty and the Agreement Establishing CROSQ.

18.	CCJ	Caribbean Court of Justice	Pursuant to Article 211 of the Revised Treaty and the Agreement establishing the CCJ.
-----	-----	----------------------------	---

ASSOCIATE INSTITUTIONS			
INSTITUTIONS			COMMENTS
19.	CDB	Caribbean Development Bank	As per Article 22 of the Revised Treaty.
20.	CLIC	Caribbean Law Institute Centre	As per Article 22 of the Revised Treaty.
21.	OECS Secretariat	Organisation of Eastern Caribbean States Secretariat	As per Article 22 of the Revised Treaty.
22.	UWI	University of the West Indies	As per Article 22 of the Revised Treaty.
23.	UG	University of Guyana	As per Article 22 of the Revised Treaty.

OTHER INSTITUTIONS WHICH HAVE A RELATIONSHIP OF FUNCTIONAL COOPERATION WITH THE COMMUNITY			
INSTITUTIONS			COMMENTS
24.	Caribbean Export	Caribbean Export Development Agency	
25.	CLE	Council of Legal Education	
26.	CTO	Caribbean Tourism Organization	

APPENDIX 3: SNAPSHOT OF KEY ACHIEVEMENTS OF THE COMMUNITY

Human and Social Development

Health

Since 1984, the Member States of the Caribbean Community have all adhered to a common regional strategy for health and health sector development. This strategy known as the *Caribbean Cooperation in Health*, is now in its third iteration and has accounted for the elimination of diseases such as whooping cough and diphtheria through common immunisation programmes.

Our Region became the first to eliminate rubella and polio. The eradication/elimination initiatives of poliomyelitis, measles and rubella were in response to the resolutions passed by the Ministers Responsible for Health in the Caribbean Community. With the support, technical advice and direction from the Pan American Health Organisation/World Health Organisation (PAHO/WHO) and other agencies, Member States implemented the activities toward elimination of these diseases. CARICOM has had no indigenous case of measles since 1991, rubella since 2001, and polio since 1999.

The Pan Caribbean Partnership against HIV/AIDS (PANCAP) established in 2001 to combat the HIV/AIDS epidemic in the Region, has overseen a decline in the rate of infections in the Region as well as a significant decline in mother to child transmission of the disease. The latter has been virtually eliminated. PANCAP has been deemed a global best practice by the United Nations for its governance structure.

The Port-of-Spain Declaration on Non Communicable Diseases (NCDs) issued after a 2007 CARICOM Summit on the issue by CARICOM Heads of Government, has resulted in a healthy lifestyle drive highlighted by an annual observance on the second Saturday of September, of Caribbean Wellness Day in all Member States and Associate Members. It has also resulted in greater enforcement of laws to eliminate the sale of tobacco to minors, as well as preparation and implementation of broader anti-tobacco legislation in some Member States.

Leadership by CARICOM on the issue of NDCs, commanded global attention and action highlighted by a UN High Level Meeting in September 2011. Since the High Level Meeting, there has been an increase in the number of countries in CARICOM with an operational policy to address NCDs, with a dedicated budget, from 32 per cent in 2010 to 50 per cent in 2013.

The Community has positioned itself to combat pandemics and other health challenges more efficiently by creating the Caribbean Public Health Agency (CARPHA) which will facilitate a coordinated approach to public health issues. Previously there were five different Agencies involved in delivering aspects of public health services support.

Education

The Caribbean Examinations Council (CXC), established in 1973, provides regionally and internationally recognized secondary school leaving examinations replacing the UK-based Cambridge systems. This has allowed for an education system that is more relevant to the needs of the Region. Some of CXC's innovative methods have been studied and introduced in third countries.

The *Caribbean Vocational Qualification (CVQ)* is based on regionally approved occupational standards and provides our artisans, tradespersons and other categories of workers with a qualification recognised throughout the Community. It provides certification which allows artisans to take advantage of the free movement of skills regime under the CARICOM Single Market and Economy.

The Caribbean Knowledge and Learning Network Agency (CKLNA) fulfilled a key regional goal with the launch of C@ribNET in February 2013. C@ribNET is a high capacity broadband regional research and educational network which links all CARICOM research and educational institutions to similar institutions in Africa (UbuntuNet), Asia (APAN, SingAREN, KOREN, and CERNET), Europe (GEANT and JANET), Latin America (redCLARA) and North America (Internet2, CANARIE and RNIE).

Culture

The Caribbean Festival of the Arts (CARIFESTA) first staged in 1972, showcases the cultural talents of the Region and brings together artists and artistes from the Community, the wider Caribbean and further afield. CARIFESTA continues to be the pre-eminent showpiece of its kind. It provides a platform and a market for artists and artistes to gain exposure and take advantage of available opportunities.

Youth Affairs

The CARICOM Youth Ambassador Programme (CYAP) is an initiative for leadership development and youth participation. The Programme was launched in 1993 as part of the Community's Twentieth Anniversary celebrations. The CARICOM Youth Ambassadors are the Community's youth focal points for deepening the regional integration and development process through advocacy and peer education initiatives. In 2013, the CARICOM Youth Ambassador Corps celebrated its Twentieth Anniversary of encouraging integration and involving their peers in activities that promote positive development.

Disaster Management

Through the Caribbean Disaster Emergency Management Agency (CDEMA), the Community has developed a comprehensive approach to disaster management. CDEMA and its predecessor, the Caribbean Disaster Emergency Response Agency (CDERA) have provided first respondents after many disasters and its efforts have brought relief to many citizens.

The Caribbean Catastrophe Risk Insurance Facility (CCRIF) is a not-for-profit entity, owned, operated and registered in the Community, to limit the financial impact of catastrophic natural disasters by quickly providing financial assistance when a policy is triggered. The Facility has provided assistance to governments and individuals.

Climate Change

The Caribbean Community is one of the regions in the world that suffers the most adverse effects of Climate Change. In response, the Caribbean Community Climate Change Centre (CCCCC) has been established and is providing advice and working with Member States to implement projects to mitigate the effects of and adapt to climate changes. The Centre has been identified as a best practice internationally and now lends advice and assistance to other threatened regions. It has also been recognised by the United Nations Institute for Training and Research (UNITAR) as a Centre of Excellence, one of an elite few.

Trade and Economic Integration

The CARICOM Single Market and Economy (CSME), inaugurated in 2006, is moving towards a single, seamless economic space. CARICOM citizens are now conducting business, gaining employment and providing services in other Member States and using the provision to move capital to invest and establish businesses within that space. This has widened the domestic market for businesses and the job market for those skills covered under the agreement by the Member States.

The Single Market has enabled intra-regional trade in goods to grow from approximately US\$600 million in 1990 to more than US\$3 billion in 2012 or 15 per cent of total trade as against 10 per cent in 2006.

The CARICOM Regional Organisation for Standards and Quality (CROSQ) was established as the regional Centre for promoting efficiency and competitive production in goods and services, through the process of standardization and the verification of quality. This has facilitated CARICOM manufacturers in being certified to meet international standards.

An Agreement on Social Security is in place which allows for transferability of pensions, and national insurance benefits between countries for workers who take advantage of the provision of free movement under the CSME.

Caribbean Court of Justice (CCJ)

The Caribbean Court of Justice (CCJ) inaugurated in 2005, is the sole judicial body with respect to interpretation of the Revised Treaty of Chaguaramas. It provides certainty and predictability to the operations of the CSME. The Court also has an Appellate Jurisdiction which will replace the British Privy Council for most Member States and complete the circle of sovereignty when they accede to that aspect of the Court.

The Court brings a Regional ethos to judicial decisions and lessens the cost of appellate litigation for those countries which no longer have the Privy Council as their final Court.

Security Co-operation

Co-operation in security matters among CARICOM Member States reached a high point during the Cricket World Cup held in the Region in 2007 which saw the establishment of an Advanced Passenger Information System (APIS) for alerting security forces about travellers of interest and the sharing of intelligence through the Regional Intelligence Fusion Centre. The APIS continues to operate. Through the APIS and border security support, which are managed through the CARICOM Implementation Agency for Crime and Security (IMPACS), an Institution of the Community, the combined effect has been a safer Community through the screening of travellers at air and sea ports. IMPACS further contributes to the safety of the Community by providing Member States with intelligence about potential threats.

CARICOM Member States provided a military battalion that participated in the multilateral and, subsequently, the United Nations peacekeeping force in Haiti in 1994-1995 where they played a key role in ensuring security and stability in Northern Haiti.

Foreign Policy Co-Ordination

The Caribbean Community's increasing co-ordination in foreign policy has resulted in the recognition of CARICOM as a valued international actor. This recognition has led to an increasing number of States seeking to have relations with the Community and CARICOM using that interest to leverage development projects and programmes for its Member States and to promote its priorities in the international arena.

CARICOM has provided three Presidents of the United Nations General Assembly (UNGA): His Excellency Rudolph Insanally (1993); Hon. Julian Hunte (2003); and His Excellency John Ashe (2013). In addition to Presidents of the UNGA, CARICOM nationals have headed peacekeeping and peace-building missions of the UN and Human Rights and Election Observation Missions of the UN and of the OAS.

CARICOM nationals have also headed the Commonwealth Secretariat, the ACP Group of States, the Pan-American Health Organisation (PAHO), as well as the ACS Secretariat and has had nationals elected as Assistant Secretaries-General of the OAS.

The attainment of these high level positions in international organisations underscore the credibility and record of excellence of the Community and its officials and diplomats on the global stage and has raised the prestige of the Region.

The Caribbean Community spearheaded the establishment of the African, Caribbean and Pacific (ACP) Group of States which has led aid, trade and development negotiations with Europe for close to 40 years. One of the halls in the European Commission and one in the Headquarters of the ACP Secretariat are named after CARICOM nationals in honour of their contributions to ACP-EU relations.

CARICOM's initiative established the Association of Caribbean States (ACS) which brought together all the countries which are washed by the Caribbean Sea in a grouping which focuses on Disaster Risk Reduction, Sustainable Tourism, Trade, Transport and the Caribbean Sea. The ACS piloted the resolution at the UN which declared the Caribbean Sea as a Special zone in the context of sustainable development.

The Community was also successful in its efforts to have the International Civil Aviation Organisation (ICAO) adopt the community of interest principle under which a country belonging to a grouping such as CARICOM and which has no airline of its own, could designate an airline of another member of the grouping to use its route rights in the conclusion of air services agreements.

CARICOM played a leading role in the negotiations for the United Nations Arms Trade Treaty which was adopted in 2013. The Treaty offers an international instrument which has the potential, among other things, to prevent the diversion to the illicit market of conventional arms, including small arms and light weapons, their ammunition, as well as parts and components.

This illicit trade which is associated with international drug trafficking and other forms of transnational organised crime has negatively impacted the societies of CARICOM.

CARICOM was instrumental in the establishment of the International Criminal Court (ICC), the first permanent, treaty based, international criminal court established to help end impunity for the perpetrators of the most serious crimes of concern to the international community. One of the Court rooms at the Headquarters is named after a CARICOM national and nationals of the Community from Guyana, Jamaica and Trinidad and Tobago have served or are presently serving on the Court. The Court has been quite active in bringing perpetrators of crimes against humanity to book.

CARICOM led the way for the recognition of small and vulnerable economies as a group within the World Trade Organisation (WTO). Small, vulnerable economies (SVEs) are those WTO members that account for only a small fraction of world trade. They are particularly vulnerable to external economic shocks and natural disasters. WTO members recognize that SVEs, while not forming an official sub-category of members, face certain risks and agreed in 2002, on a Work Programme on SVEs in accordance with the Doha Declaration.

CARICOM is one of the founders and leaders of the Alliance of Small Island States (AOSIS), a coalition of Small-Island and low lying coastal developing countries (SIDS) that share similar development challenges and concerns. That group is a major advocate on behalf of SIDS and has been instrumental in the battle for international funding for adaptation and mitigation of climate change.

The preservation of the Caribbean Sea for the people of the Region is a major objective of the Community's efforts at sustainable development. Due to the leadership role played by CARICOM jurists in the negotiations leading to successful conclusion of the Law of the Sea Convention, the Headquarters of the International Seabed Authority (ISA) was established in Jamaica.

Policies and Model Legislation

The Community has developed policies and draft model legislation in a number of areas which have assisted the individual Member States in preparing their national policies and legislation across a range of important areas for national and regional development.

APPENDIX 4: STRENGTHS, WEAKNESSES, OPPORTUNITIES, THREATS (SWOT) ANALYSIS FOR THE CARIBBEAN COMMUNITY

ECONOMIC

According to the UN,⁴⁸ the global economy slowed significantly amid recession in Europe caused by financial, fiscal and competitiveness imbalances, especially in the eurozone, as well as the slowdown in China and moderate growth in the United States. In 2013, a growing number of developed economies, especially in Europe, fell into a double-dip recession, while those facing sovereign debt distress moved even deeper into recession - many developed economies are caught in downward spiralling dynamics from high unemployment, weak aggregate demand compounded by fiscal austerity, high public debt burdens, and financial fragility.⁴⁹ A worsening of the euro area crisis, the “fiscal cliff” in the United States and a hard landing in China gave increasing cause for concern globally and the CARICOM region in particular.

The Economies of several CARICOM Member States are already in crisis. The crippling economic realities facing Member States include burdensome debt, fiscal un-sustainability and low growth, inimical to the achievement of self-sustaining economic growth.

S TRENGTHS

1. Commitment by Governments to a fully-functioning Single Market and Economy (CSME)
2. Excess Liquidity in the Banking System which could be possibly available for Intra-Regional Investments
3. An expanded intra-regional market (including Haiti)
4. Heads of Government committed to regional economic development (CARICOM Commission on the Economy)

W EAKNESSES

1. Low Growth, High Debt, Limited Fiscal Space
2. Failure to plan effectively for liberalisation
3. Dependence on a narrow range of export products
4. Low and Uncompetitive Production Activity
5. Small Economies (Diseconomy of Scale)
6. Vulnerability to External Shock
7. High Interest Rates
8. Limited Access to Credit/Capital
9. Limited Use of Excess Liquidity for Investment
10. Sub-optimal implementation of the CSME (64%)
11. Productivity below expectation
12. Low Level of Intra-Regional Trade
13. Low Level of International Export Trade,
14. Limited utilization of bilateral trade agreements

O PPORTUNITIES

1. Global Value Chains
2. Shifts in Geo-Political Arrangements
3. Globalization (Trade Liberalization and Lowering of Trade Barriers)
4. Align with Mega-Markets

T HREATS

1. Recession in developed countries
2. Shifts in Geo-Political Arrangements
3. CARICOM remaining outside of Mega-Markets
4. Dwindling External Resource Flows
5. Globalization (Trade Liberalization)

⁴⁸ World Economic Situation and Prospects, United Nations 2013

⁴⁹ Preliminary Overview of the Economies of Latin America and the Caribbean, United Nations ECLAC 2012

AGRICULTURE

The Caribbean Community has a long history of policy formulation and planning for the agricultural sector. This dates back to the late 1970s when the Regional Food Plan (RFP) was launched. The RFP was followed by: the Regional Food and Nutrition Strategy (RFNS) and the Caribbean Community Programme for Agricultural Development (CCPAD) in the 1980s; the Regional Transformation Programme (RTP) in 1996; the Regional Food and Nutrition Security Strategy in 2010; and the Caribbean Community Agricultural Policy (CAP) in 2011. There has been a shift in emphasis over time on the priorities of these programmes based on global and regional economic conditions. In more recent years, the sector has had to grapple with major changes in the trading arrangements for the traditional crops (rice, sugar and bananas) which has had severe negative consequences on agriculture's contribution to the Region's economy, employment generation and rural development. In addition, the rising food import bill, the impact of climate change on food production and the aging farming populations provide further challenges that must be confronted for an expanded and sustainable agricultural sector.

S TRENGTHS

1. Tertiary training institutions and several agricultural developmental partner agencies, regional agencies and highly qualified technical experts
2. The Region as a single market space, cross border investments
3. Traditional agricultural communities
4. Large scale agriculture investment in some Member States
5. Commodity prioritization and policy framework to support increased production and trade
6. The establishment of the Caribbean Agricultural Health and Food Safety Agency (CAHFSA)

W EAKNESSES

1. Inability to sustain and expand agriculture, fisheries and aquaculture output
2. Low productivity and high cost of energy
3. Weak linkages among current institutions
4. Inadequate research
5. Lack of legislative reform and minimal enforcement to address preadial larceny
6. Lack of reliable and affordable transportation infrastructure and modalities for the distribution of agricultural products throughout the region
7. Limited statistical evidence of the impact of climate change on agriculture
8. Climate change and meteorological policies are being developed without enough of the relevant linkages to sector related policies e.g., land, water and marine policies
9. Slow removal of the key binding constraints to agriculture
10. Limited and inadequate new investments
11. Outdated and inefficient agricultural health and food safety systems
12. Deficient and uncoordinated risk management measures
13. Inefficient land and water distribution and management systems
14. Lack of trained human resources
15. Older farming population and not sufficient engagement of youth

O PPORTUNITIES

1. Increasing global demand for alternative tourism product like Agro-Tourism
2. The increased global focus on healthy life styles and the resultant increase in demand for organically grown products

T HREATS

1. Food Security – high import food prices and recent external supply shock
2. Increased volatility of global food supplies because of climate change
3. Volatile commodity prices

TRANSPORTATION

The establishment of a Transportation Commission by the Conference of Heads of Government to address Air and Maritime transportation matters is an acknowledgement of the importance of transportation to regional development.

The international regulatory obligations of Member States set the parameters for the regional development of the two sub-sectors.

In the case of Air Transportation, thirteen (13) of the fifteen (15) CARICOM States are Contracting States of *the International Civil Aviation Organisation (ICAO)*, the regulatory body of the air transportation industry which establishes the basic principles to be followed by Governments to ensure that international air transport services may be developed in an orderly, regular, efficient, economical, harmonious and sustainable manner.

In the case of Maritime Transportation, CARICOM Member States as contracting States to the Convention on the International Maritime Organisation (IMO) are obligated to provide mechanisms for cooperation among Governments with respect to regulations and practices affecting shipping engaged in international trade and to facilitate the adoption of the highest practicable standards regarding maritime safety, efficiency of navigation and prevent and control of marine pollution from ships.

S TRENGTHS

1. Functioning Transportation Commission
2. The Region's geographical location would allow it to develop niche markets in the air and maritime industries, for e.g. servicing and refurbishing of aircrafts and sea-going vessels
3. Safety and capacity of the Regional Air Space

W EAKNESSES

1. High level of taxation on air and maritime transportation
2. High cost of intra-regional transport (maritime and air)
3. Limited airport capacity
4. Non-profitability of regional airlines
5. Increasing shortage of trained personnel
6. Lack of proper synchronizing of regional airline flight schedule and interline of carriers
7. No harmonized regional regulatory framework for port administration

O PPORTUNITIES

1. Party to the International Convention on International Maritime Organisation and International Civil Aviation Organisation
2. Requirement for safe havens for aircraft during the hurricane season
3. High cost of maintenance of pleasure and business aircraft in North America
4. Demand in the industry for the development of aircraft simulation programmes for pilot training
5. Expansion of the Panama Canal

T HREATS

1. Prevailing fragile world economic climate and resulting decrease in passenger load factors and overall profitability of airlines
2. Entry of low cost international airlines into the regional market
3. Trend towards bigger aircraft
4. Taxation imposed by international organisations to meet regulatory requirement
5. Increasing changes in the aviation industry (human resources, size of aircraft etc.)
6. International shipping challenges viz changes in Global traffic patterns and imbalance in East-West Trade route

TOURISM

According to the World Economic Forum (WEF)⁵⁰, given the volatile global environment, new capabilities in tourism management and sector development are vital if developing economies such as those of CARICOM Member States are to become more resilient against disruptive events and to prepare for long-term stability.

According to the *ITB World Travel Trends Report*, Travel and Tourism remains a strong engine of growth, representing nearly 10 percent of global economic activity if all adjacent services are taken into account. The USA remains the world's top destination for international travel with 56 million visitors, ahead of Spain (51m) and Germany (48m).

The Region is heavily dependent on Tourism. Using the WTTC formula for total economic impact of tourism (direct impact of travel and tourism plus indirect economic impact of investment), for the year 2012, the contribution of tourism to GDP for example, in Antigua and Barbuda, was 77.4%; The Bahamas 48.4%; Barbados ,39.4 %; Saint Lucia 39%; and Jamaica,27.4%,

S TRENGTHS

1. Existence of best practice models in the CARICOM Region.
2. Favourable climatic conditions as well as proximity to North America

W EAKNESSES

1. High cost of vacationing in CARICOM destinations
2. Imposition of duties and tariffs by CARICOM Member States on air passengers
3. Insufficient and inefficient marketing and promotion
4. Over saturation of “sun and sea” product
5. Vulnerability to Climate Change and growing environmental degradation

O PPORTUNITIES

1. Emerging source regions such as Asia, Russia and Latin America provide destination marketing channels for CARICOM Member States
2. Increasing reliance on technology by individuals to plan and enjoy their trips
3. Projected growth in International Tourism over the next five years
4. Increasing demand for new and varied forms of tourism experience such as adventure, medical, nature and cultural and creative tourism

T HREATS

1. Increasing occurrence of adverse media publicity in the major markets discouraging tourism travel to certain destinations in the CARICOM Region
2. Costly and inadequate access to air transportation
3. Climate Change and growing environmental degradation
4. Increased competition from other regions
5. Destination-management techniques such as advertising campaigns or the presence of industry fairs are increasingly being displaced by communicating with travelers online through various direct or indirect channels

⁵⁰ The Travel and Tourism Competitiveness Report 2013, World Economic Forum

SERVICES

The Services Sector consists of 12 sub-sectors including Business Services such as Professional Services, Communication Services (telecommunications, postal and courier), Construction Services, Distribution Services, Financial Services, Health Services, Tourism and Transport Services and is the largest sector of the CARICOM Single Market and Economy (CSME), accounting for a substantial amount of investment, employment, production and trade.

S TRENGTHS

1. CARICOM Trade Arrangements in Services with Third States (CARICOM-Cuba Trade and Economic Agreement, CARIFORUM-EU EPA)
2. Free movement of consumers
3. No restriction on the provision of Services (commercial presence)
4. Large cadre of highly trained and skilled nationals who provide high-end services
5. Increased access of foreign consumers to internal (CSME) service providers – education, health and tourism services

W EAKNESSES

1. Absence of Mutual Recognition Agreements to facilitate trade in services
2. Small size of some CSME markets and inability to sustain livelihood of some service providers
3. Weak internal channels of distribution and high dependence on imports
4. Weak cross-sectoral linkages
5. Low ICT penetration rate

O PPORTUNITIES

1. Bilateral Investment Treaties
2. Increased access of consumers to external service providers
3. Most Member States are Party to the WTO General Agreement on Trade in Services (GATS)

T HREATS

1. Visa requirements for providers and consumers
2. US Foreign Account Tax Compliant Act (FATCA)
3. Blacklisting of Low and No Tax Jurisdictions by developed countries
4. Absence of Mutual Recognition Agreements to facilitate trade in services
5. High cost of implementing international standards – ever increasing minimum qualifications

ENERGY

CARICOM economies are directly and indirectly affected by high and volatile oil prices. The major direct effects are a deteriorating trade balance, through a higher import bill and a weakening fiscal balance, due to greater government transfers and subsidies to insulate movements in international energy markets.⁵¹ Indirectly, high and volatile oil prices also have a major impact on inflation rates; they reduce consumer confidence and purchasing power, while raising uncertainty among investors, and reducing competitiveness due to higher power generation and transport costs.

S TRENGTHS

1. CARICOM Energy Policy
2. Alternative Energy Potential (Hydro, Geothermal, Wave, Wind, Biofuels)

W EAKNESSES

1. Small size of some individual economies in the Region constrains their ability to exploit their renewable energy potential
2. Inconsistency in regulatory framework across the Region
3. Grid instability and system losses
4. Inefficiencies in energy production
5. General lack of awareness of the use of renewable energy (RE) and energy efficiency (EE)

O PPORTUNITIES

1. Lowered energy cost as a result of rapid development of Shale Gas in the USA
2. South-South cooperation in Renewable Energy Technology Transfer
3. Global trend towards exploitation of renewable energy potential
4. Enhanced energy efficiency

T HREATS

1. High cost of fossil fuel
2. Rapid development of Shale Gas in the USA
3. Reliance on preferential access to energy supplies from a single source

⁵¹ <http://www.worldbank.org/>

CITIZEN SECURITY

Globalisation has provided the vehicle for the spread of crime and criminal activity that exists in the global arena to the CARICOM Region. Weaknesses and vulnerabilities in the Region’s infrastructure have also contributed to the prevalence of crime. These vulnerabilities include porous maritime Borders, weak Criminal Justice Systems and delicate small economies.

Although the Caribbean region has come a long way since the 1980's (when it served as a major trans-shipment hub for drugs entering the US), increased interdiction efforts in Mexico and Central America may inevitably move trafficking patterns back to the Caribbean. Current estimates show that no more than 5 percent of the cocaine destined for the United States flows through the Caribbean⁵² - down from 10 percent in 2006 and 26 percent in 2001.

Despite the impressive gains that have been made with respect to drug trafficking, local consumption of illicit drugs and alcohol remain major causes of the high crime and violence rates, such as is seen in homicides, domestic violence and gang violence, that plague many Caribbean countries. The young people of the Region are the most vulnerable. Regionally, the cost of crime and violence has been estimated at 2.7 % to 4% of the Gross Domestic Product (GDP).

Citizen security in the Region is also threatened by cybercrime, which is global in nature. Norton's annual cybercrime report estimates the global cost of cyber crime in 2012 at US\$110 billion).

In February 2013, CARICOM Heads of Government adopted the CARICOM Crime and Security Strategy. The Strategy provides a common platform to advance the Region’s fight against crime (for example, illicit trafficking, gang and youth violence, terrorism and cyber security) while also addressing the issue of crime prevention.

S TRENGTHS

1. Regional consensus on citizen security
2. Popular support for crime prevention
3. Regional Crime and Security Strategy adopted as a robust approach to combating crime and criminal activity within the Region
4. Advanced Passenger Information System (APIS)

W EAKNESSES

1. Low citizen confidence in security infrastructure
2. Porous maritime borders
3. Limited capacity to deal with emerging threats, e.g. Cybercrimes
4. Unequal access to relevant education, employment and other opportunities by vulnerable groups

O PPORTUNITIES

1. International Strategic Alliances/Third State Alliances
2. Increased international intelligence support
3. International shift towards the inclusion of social crime prevention strategies for addressing crime and violence
4. Greater focus on drug policies and programmes promoting alternatives to incarceration

T HREATS

1. Liberal policies regarding access to guns by Third States
2. International partners policy re relocation of involuntary migrants (deportation of criminals to the Region)
3. Mutually reinforcing relationship between transnational organised crime and criminal activities in Member States

⁵² Mark Sullivan, Congressional Research Service, “Background for February 1, 2012 Hearing on U.S. – Caribbean Security Cooperation,” Pg1.

HUMAN DEVELOPMENT

The Member States of the Region have diverse demographics and levels of human development, for example, in terms of population size, education, health and poverty status. Generally, the population across the Region is aging, with a rapid increase in persons over 60 years of age. Most households across the Community have access to a pipeborne water supply and improved sanitation with the exception of Haiti. Most nations are defined as middle and high income; however poverty levels remain a challenge. Moreover, having ‘graduated’ to upper middle-income or high-income, based on per capita GDP, many Members find it difficult to attract development funding, even though small size and island status pose particular challenges of vulnerability to external shocks, natural or man-made.

S TRENGTHS

1. Solid primary health care system in place:
2. Robust and harmonised education certification system at the secondary school level
3. Universal access to primary education
4. Increasing movement towards harmonised system of technical vocational education and training (TVET) and certification
5. Significant expansion of tertiary education
6. Establishment of the Caribbean Public Health Agency (CARPHA)
7. Clear health policy directives by Heads of Government
8. Establishment of Regional Human Resource Commission

W EAKNESSES

1. Inability to produce healthy food at a competitive price and proliferation of fast foods
2. Absence of comprehensive policies and frameworks to address the physical activity deficit, alcohol and tobacco use
3. Low Human Resource retention
4. Lack of resources for efficient maintenance of secondary care programs
5. Weak roll-out of NCD prevention policies
6. Low access to early childhood development provisions
7. Low school performance and graduates with inadequate skills
8. Inadequate integration of ICT into education system
9. Uncertified and unskilled graduates entering labour force

O PPORTUNITIES

1. International Framework Conventions guiding regional programmes and policies
2. Increased access to technologies promoting life-long learning

T HREATS

1. Little or no concessionary financing available for new health investments
2. Effect of globalization on NCD proliferation
3. Exposure to new and emerging infections
4. Mismatch between skills and requirements of economies
5. High cost of education, fostering inequalities

YOUTH DEVELOPMENT

The Report of the CARICOM Commission on Youth Development (CCYD, 2010) argues that young people comprise the sector of the population best positioned by virtue of their creative potential, to play the leading role in responding to the challenges of globalisation and, therefore, to the demands of regional integration and the CSME. The CCYD Report outlined some critical actions that need to be taken, including greater investment in the development of adolescents and youth for better returns to both country and Region; and a radical shift towards partnering with adolescents and youth to tackle many of the burning issues confronting the youth of the Region. Young people under the age of 30 comprise approximately 60 per cent of the Region's citizenry and therefore cannot be ignored.

According to the CARICOM Youth Development Action Plan (2012-2017) youth is defined as those persons between 10-29 years.

S TRENGTHS

1. Talented and skillful youth
2. Burgeoning regional entrepreneurship initiatives
3. Increased awareness of importance of youth in development
4. Captive youth population (60 % of CARICOM population can be defined as youth)
5. Deepened integration movement and widening market opportunities within CARICOM
6. Established and functioning regional youth governance structures

W EAKNESSES

1. Inadequate preparation of youth for existing and emerging opportunities in economies and societies
2. Inadequate mechanisms to facilitate meaningful youth participation in Governance at the national level
3. Inadequate resources allocated for regional youth programme
4. Absence of strategic regional youth research agenda
5. High rates of youth unemployment
6. Male under participation in education
7. Continued inability to address migration of tertiary graduates, and other skilled youth

O PPORTUNITIES

1. Increased access to technology providing increased opportunity for business, continued education and overall development

T HREATS

1. Health issues (NCDs/HIV)
2. Globalisation and amplification of negative social behaviours and cultural practices
3. Gun violence, human trafficking, drugs and other social ills impacting on lives of youth

MAINSTREAMING INCLUSIVENESS

In July 2012, the UN Secretary-General launched a High-level Panel of Eminent Persons to provide guidance and recommendations on the Post-2015 development agenda. The Panel published its Report in May 2013 titled “A New Global Partnership: Eradicate Poverty and Transform Economies through Sustainable Development” which sets out a universal agenda to eradicate extreme poverty by 2030. The first of five major transformative shifts outlined in the Report states “Leave No One Behind”. *We must ensure that no person – regardless of ethnicity, gender, geography, disability, race or other status – is denied basic economic opportunities and human rights.*

The Caribbean Community is advocating for a comprehensive and transformative Post 2015 and Small Island and low-lying coastal Developing States (SIDS) development agenda that develops measures for a people-centred approach to poverty reduction; develops measures for protection and inclusion to guarantee opportunities for the most vulnerable and disadvantaged and takes account of the transformative and multiplier effect of gender equality and empowerment of women on development activity and gains.

S TRENGTHS

1. Commitment to international conventions on gender equality and disability rights
2. CARICOM Model Legislation developed and enacted in some countries to promote gender equality
3. National Women’s/Gender Bureaux active in most countries to promote gender equality and inclusion
4. Rich diversity of cultures and heritage with strong family values and respect for elderly
5. Commitment of international community and civil society to promote equality and inclusion
6. Development of CARICOM policy frameworks and plans to promote equality and inclusion
7. Strong civil society networks

W EAKNESSES

1. Lack of legislation/public policy which facilitate mainstreaming of inclusiveness (gender, disabilities, age)
2. Inadequate early screening facilities for children with disabilities
3. Inadequate attention to training of education and other professionals to facilitate development and participation of persons with disabilities
4. Inadequate redress for people who experience discrimination based, for example, on gender, disability and sexual orientation
5. Aging population with limited income security system and lack of support for caregivers
6. Inability of HRD systems to attract and retain males
7. High level of poverty in the Region, particularly among female headed households

O PPORTUNITIES

1. International conventions and commitments to support advancement of human rights, diversity and inclusion
2. Accumulated knowledge available through research, consultation, policy frameworks, best practices to be shared and enacted
3. Institutional mechanisms in place to advance education, advocacy and policy change
4. Networks of organisations available to implement interventions

T HREATS

1. Stigma and discrimination toward people with disabilities
2. Entrenched negative social norms and beliefs

ENVIRONMENT, CLIMATE CHANGE AND DISASTER MITIGATION

The Caribbean is the second most hazard prone region in the world. Most of the countries are within the hurricane belt, susceptible to climate change and there is seismic activity throughout the region, with frequent events being recorded. Further, Member States, small land masses, population concentrations and infrastructure in coastal areas, limited economic base and dependency on natural resources, combined with limited financial, technical and institutional capacity, all exacerbate the vulnerability to extreme events and climate change impacts.

S TRENGTHS

1. Existence of institutional frameworks to address climate change and disaster management in a systematic manner
2. The Caribbean has the highest level of biodiversity resources, on a per capita basis.

W EAKNESSES

1. Inadequate mitigation and risk management instruments
2. Inadequacy of the hydrometeorological infrastructure
3. Inadequate Environment and Natural Resource Management including Land, Forests, Biological Diversity, Coastal Zone, Coral Reef, and Water Shed Management
4. Lack of economic incentives to facilitate environmental management

O PPORTUNITIES

1. International mechanisms for accessing climate financing

T HREATS

1. Continued Global Warming
2. Sea Level Rise
3. More intense hurricanes
4. Ocean acidification
5. Impacts of geological (tectonic) movements
6. Depletion of regional marine species and their habitats, and consequent impacts on sustainability of fish stocks
7. Increased vulnerability to natural disasters

INFORMATION AND COMMUNICATIONS TECHNOLOGY

According to the WTO,⁵³ Technology is a key factor in the transformation towards productivity driven growth, and affects trade by shaping comparative advantage and reducing trade costs.

New players are emerging among the countries driving technological progress, and technology transfer is becoming more regional. An implication of stronger regional spillovers is the possible development of groups of countries that become increasingly similar in terms of technology levels (“convergence clubs”). This may lead to more intra-regional trade, the emergence of shared economic interests and the evolution of stronger regional institutions.

S TRENGTHS

1. High-level support for sector in the Region beginning with the Single ICT space
2. Buildout of mature networks in the Region
3. Multiple entrants into Telecoms market
4. Well-skilled IT/ICT personnel in Government, private sector and civil society
5. Formal body of ICT professionals already in place for over ten years - Caribbean ICT Stakeholders Virtual Community (CIVIC)
6. Recognition of the utility of ICT for the development of the CARICOM Economy
7. Some Regional specialised agencies already working in the area
8. Many youth already attuned to possibilities of careers in ICT
9. Productive and other sectors available for positive addition of /linking with ICT
10. The existence of the Caribbean Knowledge and Learning Network Agency (CKLNA)

W EAKNESSES

1. Need and use of ICT not well articulated in all regional development programmes
2. Low Internet Speeds (Bandwidth)
3. Low Penetration/Usage Rates
4. High Cost of Access
5. Not all national (telecoms) sectors liberalised
6. In-effective and in-efficient coordination of business processes related to ICT
7. Need for many more practitioners in ICT field
8. Insufficient Private Sector ‘leadership’ in ICT sector
9. ICT sector under-developed or missing
10. Multiple ministries and ‘bodies’ responsible for ICT at national level
11. Insufficient ‘demonstration’ projects available in Region to enable speedy ‘buy-in’

O PPORTUNITIES

1. Rapid Advancement of Scientific Innovation and Technological Change (ability to ‘leapfrog’)

T HREATS

1. Keeping abreast of Rapid Advancement of Scientific Innovation and Technological Change
2. Demand for skilled ICT professionals in other developed and developing countries

⁵³ World Trade Report 2013, Factors Shaping the Future of World Trade – World Trade Organisation (WTO)

GOVERNANCE AND INSTITUTIONAL ARRANGEMENTS

CARICOM is a Community of Sovereign States. It is a rules-based entity established by Treaty. The role and function of the Principal Organs, Organs and Bodies of CARICOM are well defined in the *Revised Treaty of Chaguaramas Establishing the Caribbean Community including the CARICOM Single Market and Economy (CSME)* viz. the Conference of Heads of Government; the Community Council of Ministers; the Council for Finance and Planning (COFAP), the Council for Trade and Economic Development (COTED), the Council for Foreign and Community Relations (COFCOR), the Council for Human and Social Development (COSHOD) and the Council for National Security and Law and Enforcement (CONSLE). The CARICOM Secretariat is the Principal Administrative Organ. The Bodies are the Legal Affairs Committee (LAC), the Committee of Central Bank Governors (CCBG) and the Budget Committee. However, the Treaty is silent on the role/function of the regional institutions and their relationship to the Community and its Organs. Although these institutions have been established by or pursuant to a mandate of the Community, and carry out specialist functions which support the overall goals of the Community, the silence in the Treaty has resulted in a lack of clarity in practice and perception on the relationship of these Institutions to the Community. The CARICOM Secretariat is often seen as the primary or sole implementing agency for Community objectives and policies.

In addition, the Region is confronted with other governance issues, including: the limited engagement of the people of the Community in decision-making and governance; the effectiveness of the decision-making process; the slow rate of accession to the Caribbean Court of Justice (CCJ) in its appellate jurisdiction; failure to utilize some aspects of the governance structure and the lack of adequate systems to evaluate the effectiveness of the work of regional institutions and regional institutional frameworks. Further, some Organs and Bodies have not functioned fully in their roles outlined in the Treaty, while some linkages within the organisational structures are unclear (e.g., work of some of the Institutions and the work of CARICOM Secretariat.)

Other weaknesses in the governance arrangement include an inconsistent alignment between the regional agenda and priorities and the national agenda and priorities; the failure or inability of Member States to domesticate regional decisions and the slow rate of implementation of the regional integration arrangement.

Notwithstanding the above, there is a sustained interest in making the structures more efficient and effective as is evidenced by the deliberations and decisions of Heads of Government and various reports related to Governance of the Community.